

# Installation Guidelines

## FOR LEGEND HBR DOORS

### Installer

- Read instructions completely before attempting installation. Failure to follow these guidelines will void the Windsor warranty coverage, written or implied.
- Always provide a copy of these instructions to the homeowner.
- These instructions are consistent with ASTM 2112 “Standard Practice for Installation of Exterior Windows, Doors and Skylights” into common wall constructions. Contact your architect or construction professional for installation into other building designs or construction methods.
- Regional codes and environmental conditions may require installation that is different from these guidelines. It is your responsibility to ensure that local codes and ordinances are followed.

### Warning

- ⚠ **Work Safe!** Always wear proper eye and hearing protection when installing or adjusting Windsor products.
- ⚠ **Use Power Tools Properly!** To avoid personal injury, always follow manufacturers’ instructions for safe operation of power tools.
- ⚠ **Ladder Safety!** Working at elevated levels can be hazardous. Always use ladders and scaffolding properly. Consult manufacturers’ guidelines for safe use of these types of equipment.
- ⚠ **Safety Glazing!** Windsor products do not contain safety glazing unless specifically ordered that way. Use caution – injury could result if glass is broken and fragmented. Building codes require safety glazing for windows installed in certain areas. Consult your local building code official for guidelines.

### Important

- Windsor reserves the right to change the information contained in these guidelines without notice.
- Maintain a minimum of 1/4" between the door frame and any trim, siding or masonry.
- Use of Windsor products in barrier EIFS systems (synthetic stucco) is not recommended. To do so will void all warranties (written or implied) and Windsor Windows & Doors will not be held responsible for any claims or damages resulting from water infiltration.
- Steel fasteners will corrode when used with ACQ pressure treated lumber. Use corrosion-resistant fasteners (such as stainless steel) when installing doors in or around these types of materials.
- Door nailing flanges and drip caps (integral or applied) do not take the place of door flashing. All windows and doors must be properly flashed and sealed around the perimeter.
- Certain Windsor double hung products are furnished with jamb jacks. Jamb jacks are not required for installation, but rather future adjustment to the frame width at the middle of the unit. Jamb jacks should not be used in place of shims. Refer to Step 4 for shimming guidelines.

### Handling and Storage

- Always carry door units upright. Do not carry flat! Doing so could result in damage to the unit.
- Do not store units outside.



[www.windsorwindows.com](http://www.windsorwindows.com)

## Tools Needed

- Safety Glasses



- Utility Knife



- Hammer (or nail gun)



- Caulk Gun



- Level



- Ladder / Scaffolding



- Square



- Tape Measure



- Stapler



## Materials Needed

- Backer Rod
  - 1/4"-1/2" diameter closed cell foam
- Insulation
  - Minimally expanding low pressure polyurethane window and door foam
- Shims
  - Made of cedar or synthetic material
- Casing Nails
  - 16d Galvanized
- Silicone Sealant
  - 100% Silicone
- Flashing
  - Self-adhesive flexible flashing that complies with ASTM-D779
- Rigid Metal Flashing and Fasteners
  - Applied to head brickmould

## LEAD PAINT AND EXISTING WINDOW DISPOSAL:

- A) Before any remodel or renovation, make sure to identify any potential lead paint issues and take necessary steps to reduce the risk of lead contamination.
- B) The U.S. Environmental Protection Agency (EPA) has issued a “Lead Renovation, Repair and Painting Rule (RRP)” for remodelers of older homes and buildings. This rule requires training and certification in lead-safe work practices for firms performing renovation, repair or painting on homes and child-occupied facilities built prior to 1978.
- C) For more information regarding procedures for dealing with lead paint, please visit EPA’s website at [www.epa.gov/lead](http://www.epa.gov/lead).
- D) When removing existing windows, make sure to wear appropriate personal protective equipment. Extra precautions should be taken to protect others and property within the vicinity and below the removal window and surrounding components.
- E) Consult with local waste authorities on the proper recycling or disposal of old window components.

**ATTENTION! This document contains an arbitration agreement and jury-trial and class-action waivers that affect your legal rights.** By purchasing, installing or using this product without opting out as provided below, you agree to arbitrate any dispute you may have with Windsor relating to your Windsor products and to waive your rights to a jury trial and to participate in class-action or class-arbitration proceedings relating to any such disputes. **YOU CAN OPT OUT OF THIS ARBITRATION AGREEMENT AND THESE WAIVERS AS SET FORTH BELOW.**

---

## Step 1: Inspect Unit

### Before Installation:

- A) Remove all shipping packaging material (blocks, pads, protectors, stretch wrap).
- B) Inspect unit for any damage or defects.
- C) Verify that the door unit is the correct size and configuration.
- D) Contact your nearest Windsor distributor if there are any problems.

## Step 2: Prepare Rough Opening

- A) Measure and verify the size of the rough opening. The rough opening should be 3/4" larger in width and 1/2" larger in height than the frame size.
- B) For doors with clad exterior casings, additional nailer studs may be required around the perimeter of the rough opening.
- C) Verify the rough opening is flat, plumb, level and square. (Fig. 1)
- D) Take diagonal measurements to check for square. (Fig. 1)
- E) Make sure the bottom sill area of the rough opening is flat and level. Correct rough opening if sloped toward the interior, out of level or humped. (Fig. 1)
- F) Cut the weather-resistant barrier (WRB) in a "Modified I" pattern. (Fig. 2)
- G) Fold back the WRB on the sides toward the interior and staple into place. (Fig. 3)

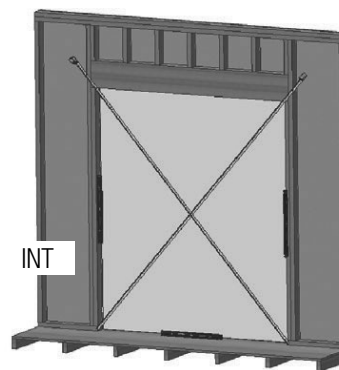


FIG. 1

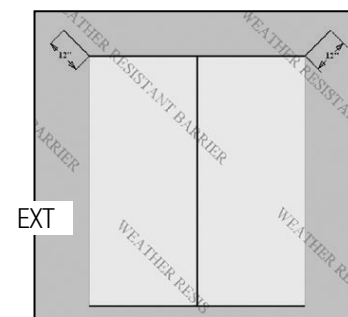


FIG. 2

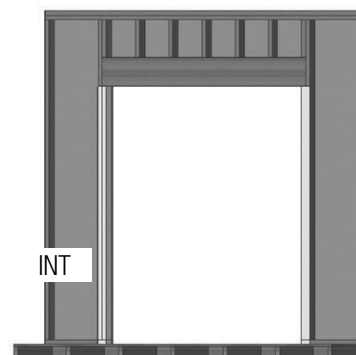


FIG. 3

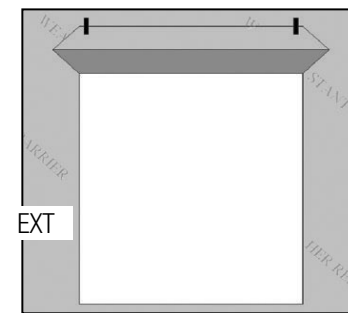


FIG. 4

- H) From the exterior, cut the top of the WRB as shown to form a flap. (Fig. 4)
- I) Temporarily tape this top flap up. (Fig. 4)

## Step 3: Flashing the Sill

### A) IMPORTANT:

- a. Use flashing that is 6" minimum in width.
  - b. Flashing must meet ASTM-D779 performance requirements.
  - c. Adhesive or mechanically-fastened flashing may be used.
- B) Measure the width of the rough opening. Cut a length of flashing that is 12" wider than the rough opening. This will allow you to run the flashing 6" up each side.
- C) Cut 1-1/2" slits at each end of the flashing as shown below. (Fig. 5)

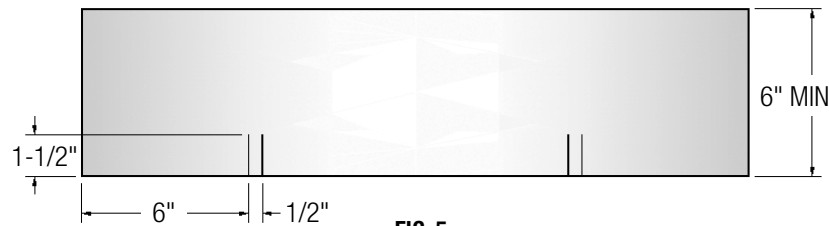


FIG. 5

- D) Apply sill flashing to the rough opening as shown below. (Fig. 6)
- E) Flashing tape must cover the entire sill. If needed, apply an additional flashing piece over the first one (start from the exterior and work toward the interior). Maintain a minimum 1" overlap. (Fig. 7)
- F) Cut and apply flashing to both sides and the top of the rough opening. Overlap the top flashing over the side flashing. The flashing should run at least 6" past each side of the rough opening. (Fig. 8)

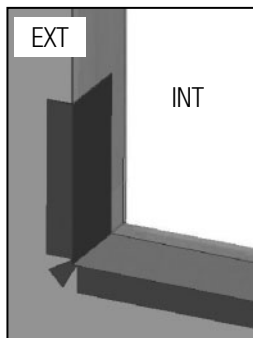


FIG. 6

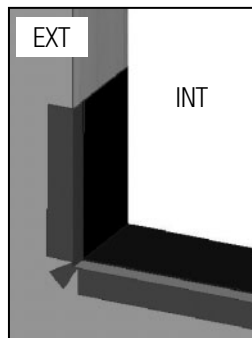


FIG. 7

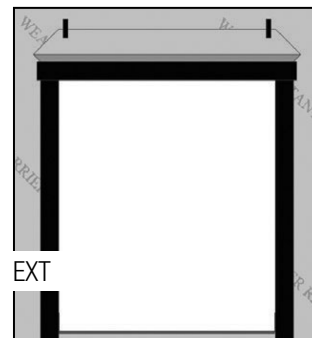


FIG. 8

## Step 4: Door Installation

*For Impact-rated products and/or any products installed in the Florida or Texas TDI regions, supplemental anchoring methods may be required. Refer to supplemental instructions attached to unit or [www.windsorwindows.com](http://www.windsorwindows.com) for further information.*

- A) Remove all packaging material (blocks, pads, protectors, stretch wrap).
- B) Inspect and verify the following:
- a. The door unit is the correct size and configuration.
  - b. The unit is free from any damage or defects.
- C) Contact your nearest Windsor distributor if there are any problems with Step B above.
- D) Apply sealant on the backside of the head and side brickmould. Apply a 1/4" continuous bead of silicone along the entire length a 1/4" from the outside edge of the brickmould. (Fig. 9)

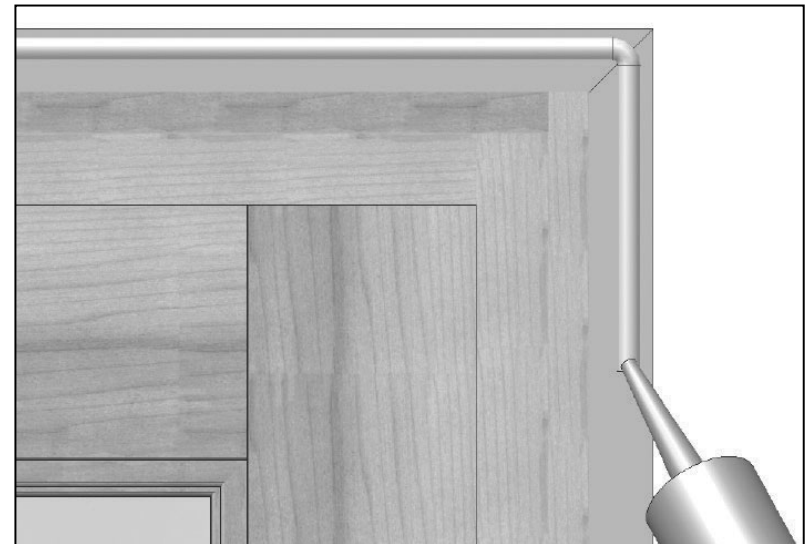
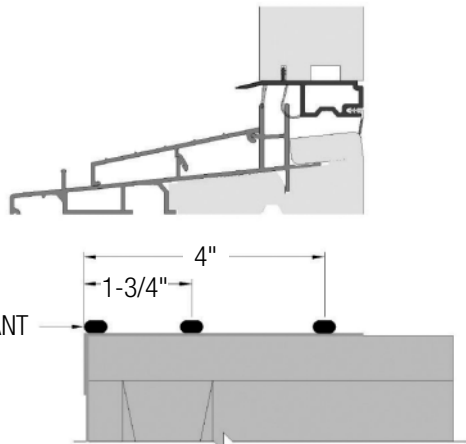
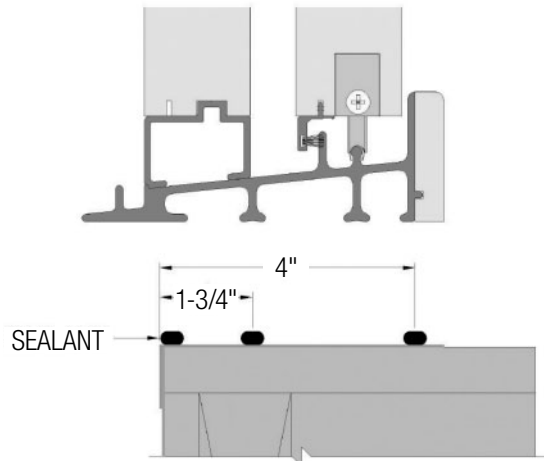


FIG. 9

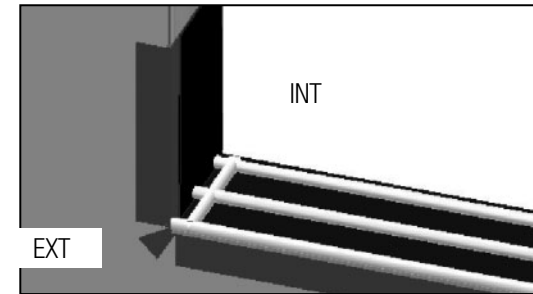
- E) Apply sealant to sill rough opening (Skip Step E for the handicap sill option):
- Apply three 1/4" continuous beads of silicone across the entire width of the rough opening. Note that the locations are different for each door type. Figure 10 shows the silicone location for a 4-9/16" and 6-9/16" in-swing door. The bead location will be different for other jamb sizes. (Fig. 9, 10 & 11)
  - Apply a 1/4" continuous bead of silicone 1/2" from each side of the rough opening. The bead will run the entire depth of the jamb starting at the face of the wall. (Fig. 12)



**FIG. 10: 4-9/16" & 6-9/16" IN-SWING PATIO DOOR SILL**

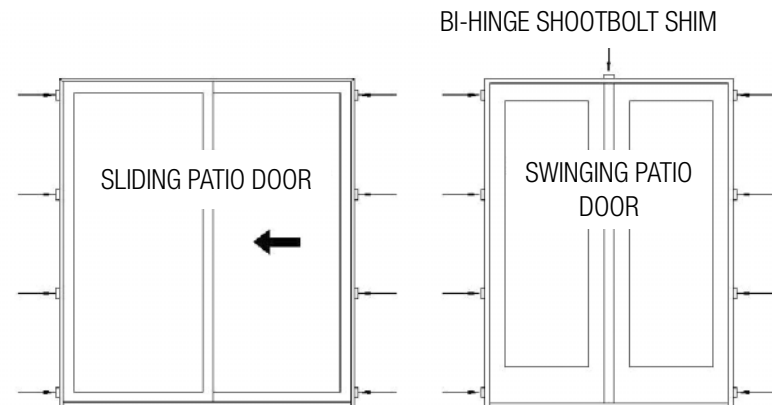


**FIG. 11: SLIDING PATIO DOOR SILL**



**FIG. 12**

- Set the door into the rough opening. Center the unit in the opening, making sure there are equal gaps on both sides of the door.
- Temporarily tack the door in place using 16d nails through the brickmould. Place the nails within 4" of each corner. Do not drive the nails in fully.
- Start with a shim at each corner no more than 1" from the jamb corner. Add additional shims spaced evenly from the center of the unit. Make sure shims are spaced no more than 16" apart. Use flat shims or pairs of triangle shims to ensure the jamb does not twist. (Fig. 13)
- Additional shims are required at each lock point, head shootbolt and hinge location for all operating doors. (Fig. 13)
- Nail all four corners in place through the brickmould.
- Finish nailing the door into place through the brickmould. Space the nails 8"-10" apart.



**FIG. 13**

## Swinging Patio Doors

- L) Apply the supplied #10 x 2-1/4" screws through each hinge, securing the hinges and frame to the rough opening. Additional shims are required behind each hinge. (Fig. 14)

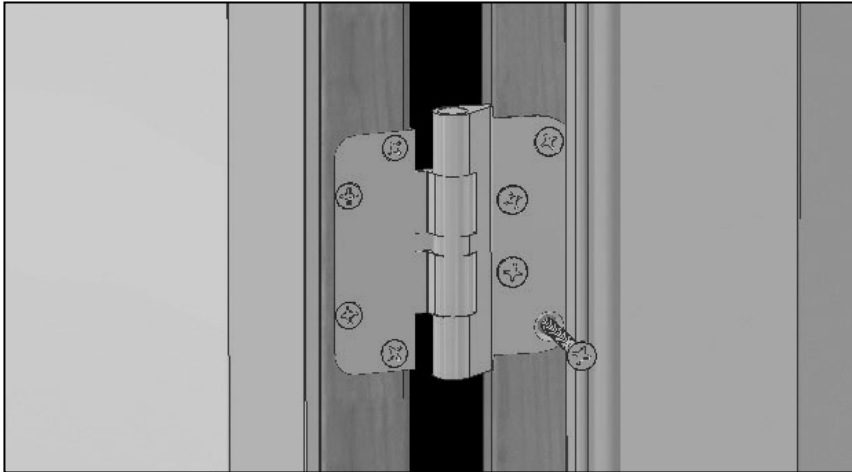


FIG. 14

## Step 5: Verify Operation

- A) Verify the operation of the door is correct. By doing so you will verify that the door either swings or slides without binding on another member of the door and by remaining motionless throughout the operation when left in a static position.
- B) If the operation of the door is not correct, first verify that the rough opening is flat, plumb, level and square. Second, verify that the door is shimmed and fastened properly as stated in these instructions. Third, verify that the rollers and hinges are adjusted to the optimal position. Refer to Step 9: Completing the Installation and review the Care and Use Guide at [www.windsorwindows.com](http://www.windsorwindows.com) for further information on hardware adjustments. Also, a supplemental hinge adjustment sheet is included with the hinge and strike plate screwpack, which can be used as a quick reference guide.

Installation Fasteners			
Substrate	Fastener	Type of Steel	Minimum Embedment into Framing
Wood	16d Finish Nail	Galvanized, Stainless Steel, Zinc Plated	2"
Wood	#6 Wood Screw		2"
Steel	#8 Self Tap/Drill Screw		Fully Threaded

## Step 6: Completing the Sill

- A) Attach a sill support block beneath the sill. Apply a bead of sealant at the nose of the sill and support block. Continue the bead of sealant around the bottom edge of the brickmould to the rough opening. (Fig. 15 & 16)

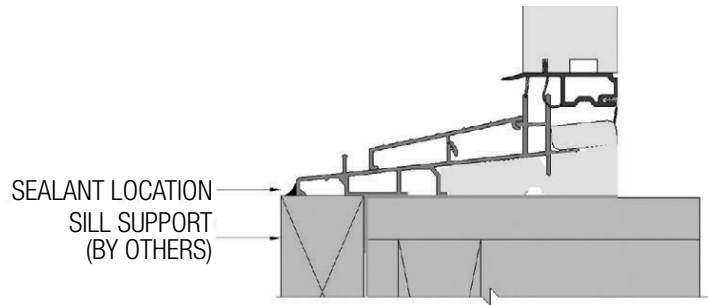


FIG. 15: STANDARD DOOR SILL

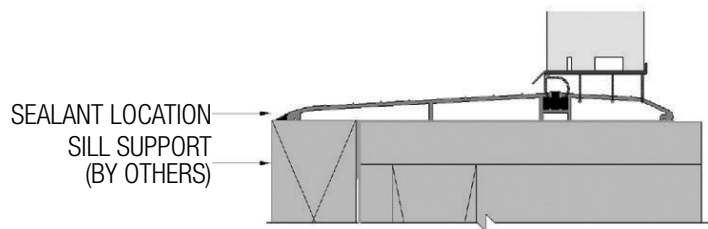


FIG. 16: HANDICAP DOOR SILL

- B) For in-swing patio doors: Apply silicone to seal each end of the sill cavity that protrudes out from the brickmould, including handicap sill. (Fig. 17)

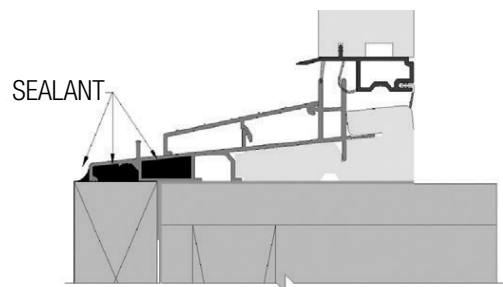


FIG. 17: IN-SWING DOOR SILL

## Step 7: Complete Head Flashing

- A) Apply sealant: Apply a bead of sealant at the vertical and horizontal contact surface of the rigid metal flashing. (Fig. 18)
- B) Apply the rigid metal flashing. The flashing should extend approximately 1/8" past the edge of the brickmould on each side. Nail the flashing to the rough opening using at least a 1" roofing nail every 8"-10" approximately 1/2" from the top of the rigid flashing. Ensure that the nail is compatible with the rigid flashing material to prevent corrosion. (Fig. 18 & 19)
- C) Overlap the WRB over the rigid metal flashing. Trim the excess WRB beyond the bead of sealant. (Fig. 19)
- D) Tape the cut seams of the WRB. (Fig. 19)

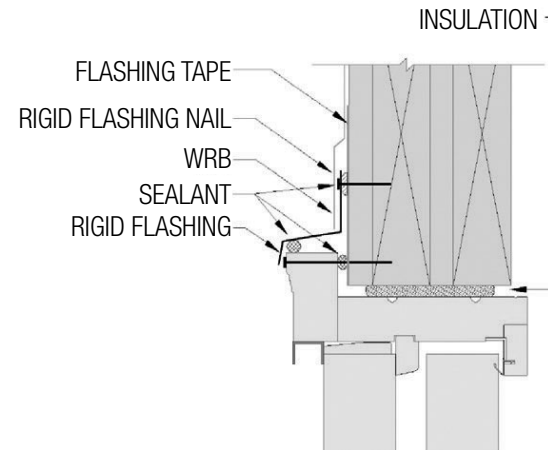
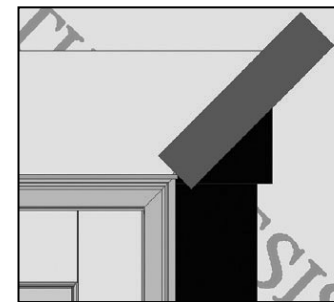


FIG. 18: HEAD JAMB



*Note: Rigid flashing must run at least 1/8" past the brickmould.*

FIG. 19

## Step 8: Seal the Exterior

- A) After siding or wall exterior is complete, apply backer rod and sealant between the door frame and siding material on both sides. (Fig. 20)
- B) **WARNING:** Maintain a minimum of 1/4" between the door frame and any trim, siding or masonry. Failure to do so will forfeit all warranties (written or implied). Windsor Windows & Doors will not be held responsible for any claims or damages resulting from failure to follow these instructions.

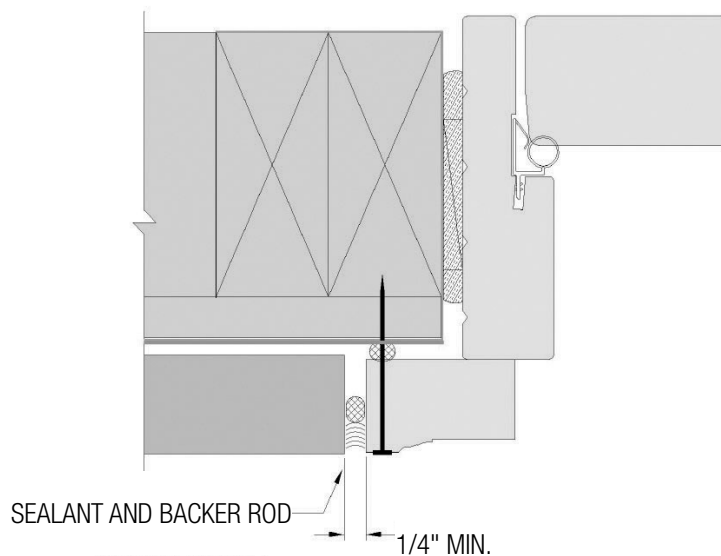


FIG. 20: SIDE JAMB

## Step 9: Completing the Installation

- A) Remove all labels or shipping materials.
- B) Various hardware adjustments may be required after installation. See the Care and Use Guide located at [www.windsorwindows.com](http://www.windsorwindows.com) for further details.
- C) Sliding patio doors: After the operating panel and keeper are adjusted to the optimal position, apply the supplied #10 x 1-1/4" screws through the top and bottom holes of the keeper. Pre-drill the holes using a 1/8" bit prior to assembly. (Fig. 21)
- D) Insulate between the door frame and the rough opening using minimally expanding window and door spray foam insulation. Use caution to not overfill the gap, causing the jambs to bow. It is not recommended to apply trim to the unit until the foam has cured to allow the excess to escape. (Fig. 18 & 20)
- E) Operate door unit to ensure proper operation. The panel will not operate correctly if the door is out of square, over-shimmed or over-insulated.
- F) Properly finish all interior wood components within 60 days of installation. See the Care and Use Guide at [www.windsorwindows.com](http://www.windsorwindows.com) for further details on finishing Legend HBR doors.
- G) **IMPORTANT:** Do not stain or paint any hardware or vinyl components.
- H) Apply the handle set as appropriate per manufacturers' recommendations. Complete final adjustments as necessary.
- I) Sliding and swinging doors are to remain closed and locked during construction to prevent site conditions from damaging and/or warping panels and frames. Allow 10-12 weeks from project completion for building temperature and humidity levels to stabilize and door panels to acclimate.

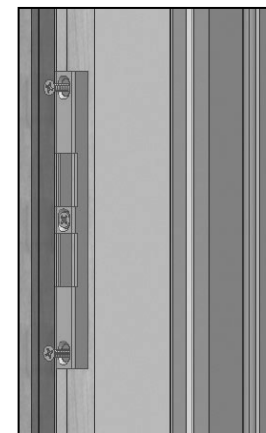


FIG. 21



## CAUTION! READ BELOW BEFORE PAINTING

**When painting cellular PVC products with darker paint colors (L values of 56 or below) UV irradiance can generate high localized temperatures in the product.**

**WARNING:** Painting of any cellular PVC surface with a paint color darker than L value of 56 (where black = 0 and white = 100) will forfeit the product warranty.

**If you should, despite the above warning, choose to use darker colors for cellular PVC paint, a paint specifically designed for these applications MUST be used. Contact the paint manufacturer to verify the paint's reflective properties and the suitability for painting cellular PVC.**

**If you have questions regarding the installation or adjustment of your Windsor products, please contact Windsor Windows & Doors directly at 1-800-218-6186.** You may also complete and submit the form on the Contact page of our website ([www.windsorwindows.com/contact-us](http://www.windsorwindows.com/contact-us)) and one of our window specialists will promptly answer your question. On our website, you will also find Care and Use Guides to assist you in preserving your windows and patio doors.

## Care and Use

An inspection of your doors should be made annually. Visit the Windsor website ([www.windsorwindows.com](http://www.windsorwindows.com)) or contact your local independent Windsor distributor for information on the care and use of your product. Ask for the Care and Use Guide, which contains information on finishing, cleaning, what to look for during yearly inspections, general maintenance tips, sash/panel adjustment, sash/panel removal, screen removal and information on condensation.

## LEGEND – Limited Warranty

Windsor Windows & Doors, as manufacturer, warrants from the date of manufacture that all Legend windows and patio doors will be free from defects in materials and workmanship that significantly impair their operation and proper usage, subject to conditions and limitations within. This warranty is transferable to subsequent structure owners, up to the time limits of the warranty. To achieve optimum performance from your Windsor products, and to preserve the warranty, please refer to the Windsor Care and Use Guide on our website, [www.windsorwindows.com](http://www.windsorwindows.com).

Windsor would like to thank you for selecting our Legend products. We are confident that they will provide you with comfort, aesthetics and value for many years to come. As with any product warranty, there are certain limitations and disclaimers that must be included so that all parties are assured that the product is being installed and used properly. Our intent is to make this warranty as clear and user-friendly as possible.

Legend products carry a **“Limited Warranty,”** which provides coverage for insulated glass seal failures for 20 years, cellular PVC components for 25 years and materials for 10 years. In addition, we are now introducing optional extended life exterior aluminum surface finishes that extend the warranty on such finishes to a period of 30 years (see #5 for details).

There are five primary components to Legend products, and the assurances and warranty provisions are specific to each:

- 1. Insulated glass used in Legend products: 20 years** – Windsor warrants that, from the date of manufacture, and under normal conditions, the insulated glass will not develop any material visual obstructions as a result of premature failure of the insulated glass seal. If a failure of seal occurs, Windsor will provide replacement insulated glass only, for 20 years free of charge. Replacement glass will be shipped F.O.B. factory. *NOTE: There is no coverage for any associated costs, such as installation, disposal or refinishing.*
- 2. Cellular PVC components: 25 years** – Cellular PVC components are warranted to not rot, warp, blister, corrode or flake under normal conditions for 25 years from date of manufacture. If any repair or replacement is necessary, such repair or replacement is warranted for the remainder of the warranty period.

**3. All other parts and components: 10 years (including, but not limited to, such items as weatherstrip and hardware)** – Window and door hardware components are usually manufactured by others and purchased by Windsor for use in our products. Windsor warrants its Legend hardware components against premature component failure that substantially impairs the operation or performance of these products. In the event of such a failure, Windsor will provide no-charge replacement parts, for this limited warranty, against defects under normal conditions for 10 years. Usually the current model will be provided; however, since Windsor purchases many of these items from others, Windsor cannot guarantee that the exact model or design of hardware will be available in the future, and usually, the current model will be provided. Any component or product repaired or replaced is warranted for the remainder of the original warranty period. *NOTE: here is no coverage for any associated costs, such as installation, disposal or refinishing.*

**With Legend HBR, the use of aluminum exterior finishes apply, and with this application the following component applies:**

#### **4. Window Sash Opening Limiting Devices**

- Always refer to applicable building codes when considering the purchase, installation and application for use as a Window Opening Control Device (WOCD). Also, refer to ASTM F2090-10 for additional information.
- If Window Sash Opening Limiting Devices are going to be installed, carefully follow all information provided with the Window Sash Opening Limiting Devices, including installation, operation and safety information. *Proper installation of Window Sash Opening Limiting Devices, pursuant to applicable building codes, ASTM F2090-10, and the included installation information, along with application of tags/labels including the safety instructions left attached for the homeowner, allows these devices to be used as Window Opening Control Devices.*
- Supervision is still required around windows where Window Sash Opening Limiting Devices have been installed.

#### **5. Exterior aluminum surface finishes**

**AAMA 2604:** Standard finish – 20-year warranty\*

**AAMA 2605:** Optional upgrade – 30-year warranty\*

**Anodized:** Optional upgrade – 5-year warranty, no warranty for coastal applications\*

- Warranty: Windsor warrants that exterior aluminum surface finishes, when exposed to normal atmospheric conditions, will not peel, check, crack, blister, flake or lose adhesion. This warranty begins on the date of manufacture. Please be aware that exterior aluminum surface finishes will weather and fade over time in any environment. Weathering, chalking and fade will vary depending on conditions, such as exposure to heavy salt spray environments, airborne pollution, elevation, orientation, altitude and other atmospheric conditions. To prolong the life and appearance of the finish coating, it is required that exterior cladding be cleaned and maintained according to a scheduled maintenance program. If paint failure should occur, Windsor reserves the right to determine the best method for corrective action.
- See Windsor's website, [www.windsorwindows.com](http://www.windsorwindows.com), for cleaning and maintenance instructions; also refer to AAMA 610.1-79. Windsor's website has additional information about each of the available finishes.

\*Coastal applications: Applies where units are installed within one mile of the coast. For all finishes except anodized, warranty period is limited to 10 years for these applications.

**The remedies provided in this limited warranty will be forfeited by the occurrence of any of the following conditions:**

- Improper installation of the window or door unit. (Installation instructions are factory applied on each unit.)
- Failure to properly finish/protect/maintain windows, doors and their components within 60 days of installation will forfeit any and all warranties for finishes, as well as warranties applicable to materials and components related to the finish. Failure to properly finish/protect wood components, CPVC components and/or all interior surfaces within 60 days of installation according to finish manufacturers' recommendations and industry standard finishing methods. Failure to properly maintain any and all finishes, interior or exterior, including finishes applied to components made from CPVC, wood, vinyl or aluminum. (See Windsor's Care and Use Guide at [www.windsorwindows.com](http://www.windsorwindows.com).)
- Damage caused by acts of God or some other cause outside Windsor's control.

**WARNING: PAINTING of cellular PVC or any PVC surfaces with a paint not specifically formulated for PVC materials will forfeit the product warranty.**

**WARNING: PAINTING of cellular PVC or any PVC surfaces with a color darker than L-56 (on the scale where 0=black and 100=white), even with a paint specifically formulated for PVC, will forfeit the product warranty.**

- Conditions that exceed the design parameters of the windows.
- Improper removal of any permanent warning or identification labels from the product or products.
- Installation in a non-vertical or sloped application.
- Damage from accident, misuse or abuse.
- Alteration, modification or use for a purpose other than that for which it was intended or designed. (Including, but not limited to, paint applied to vinyl and damage resulting from security systems applied or attached to our product.)
- Application of any tint, UV limiting or sun blocking film to either interior or exterior surfaces of the glass, or the use of film shades.
- Use in or around ships, boats, trailers, campers, swimming pools, hot tubs, spas, saunas or greenhouses.
- Installation exceeding 5,000 feet above sea level, unless high altitude breather tubes have been factory installed.
- Exposure to harmful chemicals.
- Mulling (connecting or attaching) Legend product(s) to those of another manufacturer.
- Failure to follow Windsor's Care and Use recommendations. (See Windsor's Care and Use Guide at [www.windsorwindows.com](http://www.windsorwindows.com).)
- Failure to maintain painted interior finishes. (See Windsor's Care and Use Guide at [www.windsorwindows.com](http://www.windsorwindows.com).)
- Failure to comply with the claims procedure outlined herein.

**Exclusions – The following items or conditions are specifically excluded from the remedies provided by this warranty:**

1. Remedies requested for any labor for removal, repair or replacement of defective parts, products or glass, or any repainting or refinishing costs, except as noted above.
2. Remedies requested for any consequential, incidental or punitive damages.
3. Remedies requested for damage caused by or adjustment required from:
  - a. Improper handling, installation or maintenance and/or delivery by others.
  - b. Exposure to conditions beyond performance specifications and/or design limitations.
  - c. Water infiltration other than as a result of a manufacturing defect.
  - d. Condensation and damage caused by the failure to resolve condensation.
  - e. Damage to glass, metal, cellular PVC, PVC or any other surfaces caused by brick wash, sanding, improper cleaning/washing, chemicals or airborne pollutants.
  - f. Minor scratches, and/or minor glass imperfections that do not impede or severely obstruct normal viewing area, and do not impact the structural integrity of the insulated glass.
  - g. Reflective distortion of any kind, including, but not limited to, color, tint, hue or waves inherent to annealed, coated, laminated and tempered glass.
  - h. Heat gain, vinyl distortion or damage of any kind, including, but not limited to, effects due to the reflective properties of glass and its finishes.
  - i. Alignment/location of inner grids of less than or equal to 1/8" from specified location.
  - j. Stresses to product caused by building defects, movement of the building in which the windows are installed, and/or components of that building, including building settlement.

- k. Catastrophic weather or acts of God, including fire, wind or wind-blown objects.
  - l. Normal weathering, wear and tear.
4. Any applicable taxes and freight. (Replacement parts will be shipped to the closest Windsor distributor at Windsor's expense, or the option to ship directly to the homeowner at the homeowner's expense.)
  5. Remedies requested for glass breakage, including stress cracks, unless Windsor determines that the breakage or cracking is the result of a manufacturing defect.
  6. Remedies requested for special glazing.
  7. Laminated and/or impact glass will have a warranty limited to five years against delaminating of inner liner (PVB) and extensive visual obstruction due to glass seal failure.
  8. Windsor does not warrant the percentage of inert gas present in high-performance products. Gas dissipates over time at different rates depending upon use and conditions.
  9. Remedies requested for inner grid rattle due to lack of uniform supported structure of product, in which the operation of the product or of another product causes vibration harmonics into the Windsor product and induces inner grid to vibrate against the insulated glass, creating a noise.
  10. Remedies requested for brass and oil rubbed bronze hardware finishes for finish loss, tarnishing or wear.
  11. Remedies requested for corrosion, tarnishing or operation of standard hardware in high salt spray environments.
  12. Remedies requested for anodized aluminum exterior finish variances in appearance if color, dielines, pitting and chalking are not warranted.
  13. Remedies requested for wood texture, color variations and other wood characteristics within Windsor's specifications.
  14. Remedies requested for natural warping of wood components unless the "warp" exceeds 1/4"; warping includes bowing, cupping and twisting.
  15. Remedies for swing doors over seven feet tall, without factory installed multi-point locking hardware, as these products are not warranted against warping or performance.

16. Remedies for any special or custom product or item that is manufactured according to specification provided by the customer.
17. Remedies requested for any product in a size that is greater than that shown in our catalog; these products are purchased "as is" without any warranty.
18. Remedies requested for any product purchased without factory installed glazing; these products are purchased "as is" without any warranty.
19. Remedies requested for any product installed in structures that do not allow for proper management/drainage of moisture, including, but not limited to, exterior insulation and finishing systems (EIFS) or "synthetic stucco" without engineered drainage system.
20. Remedies requested for products manufactured by others.

**Limits of Liability – Where lawful, this warranty is in lieu of all other warranties, expressed or implied, including any implied warranties of merchantability or fitness for a particular purpose.**

- No distributor, dealer, employee, salesperson or representative of Windsor has any authority to change or modify this warranty in any way.
- Windsor is not liable for any consequential, incidental or punitive damages, costs of installation of replacements or costs of refinishing window or door components or adjacent parts/millwork.
- Windsor shall make the final determination as to whether or not a defect exists.
- In addition to, or in lieu of remedies provided herein, Windsor, at its sole discretion, may repair or replace a defective part or product, or refund a portion of the original purchase price.
- Windsor reserves the right to perform warranty work or arrange for another party to perform warranty work.
- In no event shall the liability of Windsor Windows or any seller of Windsor products arising out of a product defect exceed the original purchase price of the product.
- In the event any provision is found to be unenforceable, the remaining provisions shall remain in full force and effect.

- Any component or product repaired or replaced pursuant to this warranty is warranted for the remainder of the original warranty period.
- Affixed to Windsor's windows are stickers identifying various WDMA and NFRC ratings. These ratings are not performance warranties because window performance will be impacted by conditions and may change over time. These ratings may also apply to single units only, not mulled configurations.
- This is not a warranty of future performance. It is only a warranty to provide the remedies described herein.
- Windsor is not responsible for determining the suitability of its products for particular applications and locations. Nor is Windsor responsible for compliance with building standards, including applicable building codes.
- Windsor makes no warranties whatsoever with respect to accessories or parts not supplied by the manufacturer.
- Windsor may elect to perform repairs in situations where Windsor does not believe any warranty violations exist. This does not constitute a waiver of any of the provisions of this warranty.

### **Warranty Claim Procedure**

If you have any questions regarding this warranty or have a claim under the provisions of this warranty (your "Claim"), please contact your local authorized independent Windsor distributor or one of our manufacturing facilities listed on the back of this brochure. To process a Claim, you must furnish the glass code (numbers and/or letters printed within/upon the insulated glass unit). If you have questions about locating the glass code, please contact one of the Windsor facilities OR REFER TO THE SUPPORT PAGE ON OUR WEBSITE. You must notify your local independent Windsor distributor or Windsor of any defects within a reasonable time, but no later than 30 days after the defect is discovered or reasonably should have been discovered, and within the period covered by the warranty. Windsor may require any defective parts be returned to Windsor or our closest distributor. In order to process a Claim, Windsor reserves the right to inspect the product before it is removed or modified in any way. Windsor field visits may result in service charges if a non-warranty site survey is required and/or requested.

### **Response by Windsor**

Windsor will have 30 days to respond to your Claim, with an explanation of what Windsor is willing to do relative to your Claim. Please keep in mind that this response may include an explanation of some action Windsor would like to take, such as conducting further investigation, or it may state that Windsor is not willing to take any action. We point this out to make it clear that Windsor is committing to respond to your Claim, not agreeing to remedy the problems described in every Claim it receives. If you are in any way dissatisfied with Windsor's response to your Claim, you must follow the steps of Windsor's Dispute Resolution Process as outlined below.

## **Dispute Resolution Process**

You and Windsor agree that any Dispute arising out of or related to the Windsor products shall be resolved pursuant to the terms of the Dispute Resolution Process defined in this warranty. The term "Dispute" shall mean any and all claims based on any theory (including, but not limited to, contract, warranty, tort, product liability, strict liability, fraud, consumer protection, subrogation or any other applicable statute, regulation, ordinance or common law) arising out of or related to your Windsor products (including, but not limited to, the design, manufacture, sale, distribution, marketing, warranty, service, use, performance, installation or purchase of your Windsor products) and/or the validity or enforceability of this Warranty and/or the Arbitration Agreement.

## **Notice of Dispute**

The first step in the Dispute Resolution Process is for you and Windsor to attempt to resolve your Dispute informally. To initiate the Dispute Resolution Process, you must provide Windsor with a Notice of Dispute. You can do so either by visiting [www.windsorwindows.com/support](http://www.windsorwindows.com/support), which will take you to a form that you need to complete, or by calling Windsor at 1-800-218-6186.

## **Response by Windsor**

Windsor will have 60 days to respond to your Notice of Dispute by providing a written explanation of what Windsor is willing to do relative to your Dispute.

## **Arbitration Agreement and Jury-Trial and Class-Action Waivers**

If you and Windsor are unable to informally resolve your Dispute to your satisfaction, you may seek to formally resolve your Dispute through arbitration. BY PURCHASING, INSTALLING OR USING THIS PRODUCT WITHOUT OPTING OUT AS PROVIDED BELOW, YOU AGREE TO ARBITRATE ANY DISPUTE YOU MAY HAVE WITH WINDSOR RELATING TO YOUR WINDSOR PRODUCTS AND TO WAIVE YOUR RIGHTS TO A JURY TRIAL AND TO PARTICIPATE IN CLASS-ACTION OR CLASS-ARBITRATION PROCEEDINGS RELATING TO ANY SUCH DISPUTES. The full terms and conditions applicable to this Arbitration Agreement and these waivers are set forth in Windsor's "Arbitration Agreement," which is incorporated herein by reference and is available at [www.windsorwindows.com/support](http://www.windsorwindows.com/support) or by calling Windsor at 1-800-218-6186.

## **Arbitration Opt-Out Option**

YOU CAN OPT OUT OF THE ABOVE ARBITRATION AGREEMENT AND WAIVERS. To do so, you must notify Windsor within 90 calendar days of the date you purchased or otherwise took ownership or other interest in your Windsor products either by visiting [www.windsorwindows.com/support](http://www.windsorwindows.com/support) and completing the Opt-Out Form located there, or by calling Windsor at 1-800-218-6186. Opting out of the Arbitration Agreement will not affect the coverage provided by any warranty applicable to your Windsor products.

## **Failure to Follow Procedures or Processes**

The failure to follow any of the steps outlined in the Claims Procedures or Dispute Resolution Process sections of this document does not alter, waive or void any of the terms of this document. Opting out, as described above, is the only way to alter, waive or void the Arbitration Agreement and waivers described herein.

## **Applicable Law and Severability**

This Dispute Resolution Process, including, but not limited to, issues related to its enforceability and effect, will be governed by the laws of the State of Minnesota without regard to conflict of law principles. If any term(s) of this Dispute Resolution Process, Arbitration Agreement and/or waivers is/are found to be invalid or unenforceable in any particular jurisdiction, that term will not apply to that issue in that jurisdiction. Instead, that term will be severed with the remaining terms continuing in full force and effect.

***Effective on Legend products manufactured after 1/15/2018.***