

Pinnacle Impact Series

CLAD DIRECT SET

SECTION DETAILS: SHAPES OPTIONS

SCALE: 3" = 1'-0"

Direct Set Shapes Chart

Units must be ordered by FRAME DIMENSIONS only

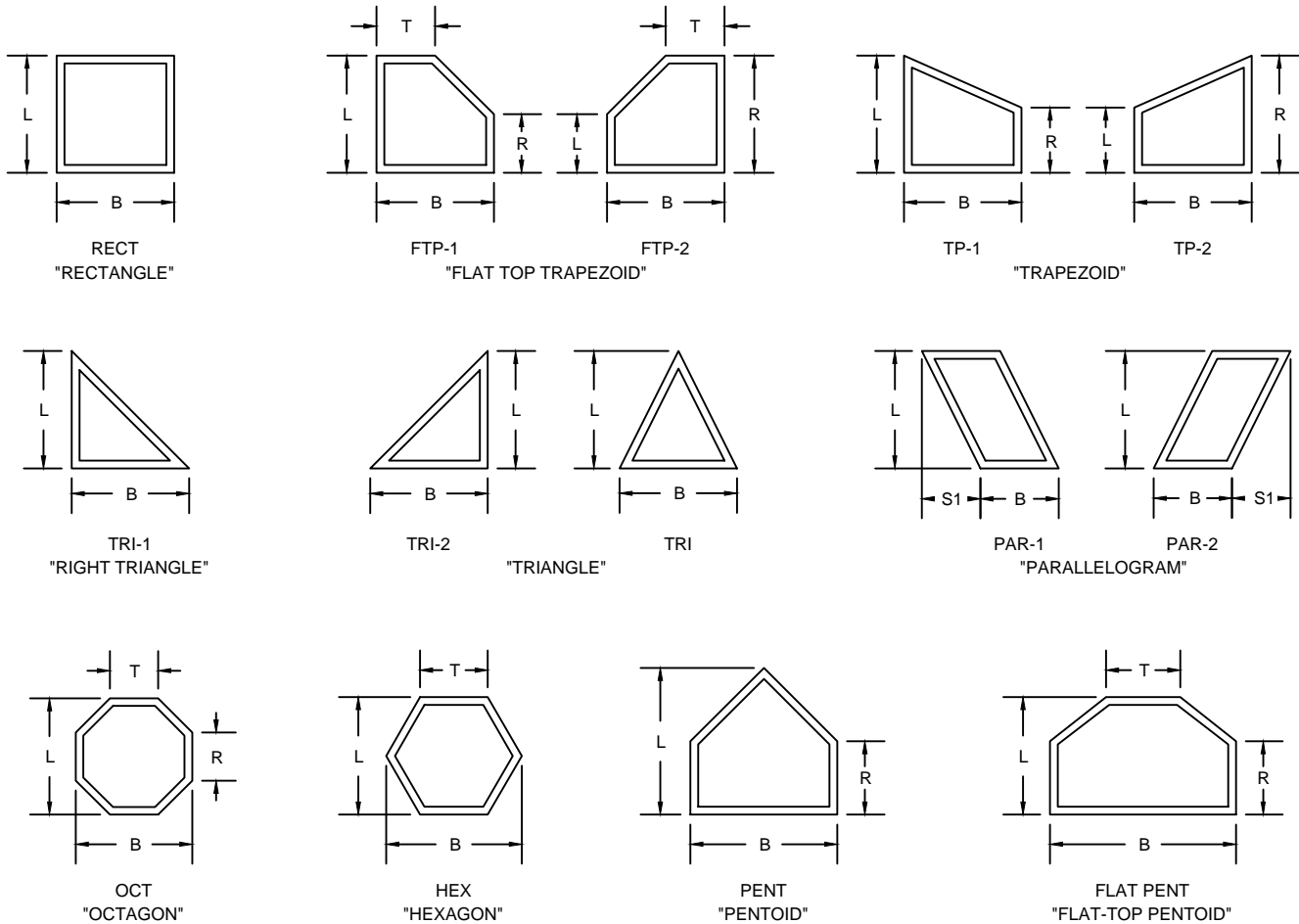

Size Limitations

1. The maximum dimension is 60" x 102" or 102" x 60"
2. The minimum base dimension is 14 inches.
3. The minimum leg dimension is 6 inches.
4. The maximum Square Footage allowed is 42 Square Feet.
5. The minimum pitch is a 5/12 angle.
6. The Aspect Ratio is 7 to 1 maximum.
7. Any one unit can not have glass smaller than 8" x 12".
8. Some spacer may be visible on units with tight angles.

Pinnacle Impact Series

CLAD DIRECT SET

SECTION DETAILS: DIRECT GLAZE

SCALE: 3" = 1'-0"

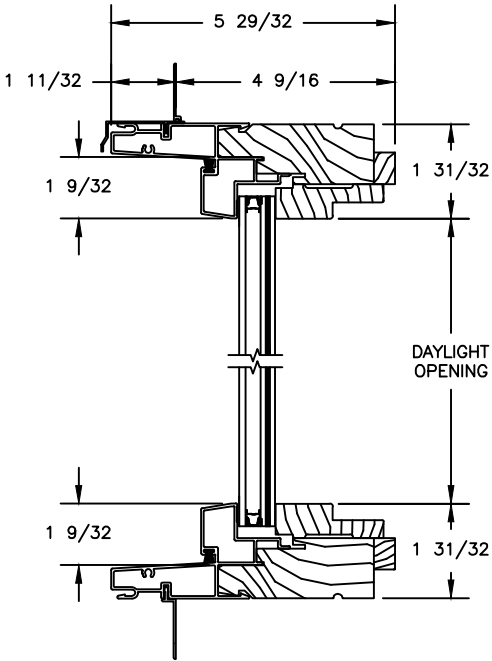

HEAD JAMB & SILL

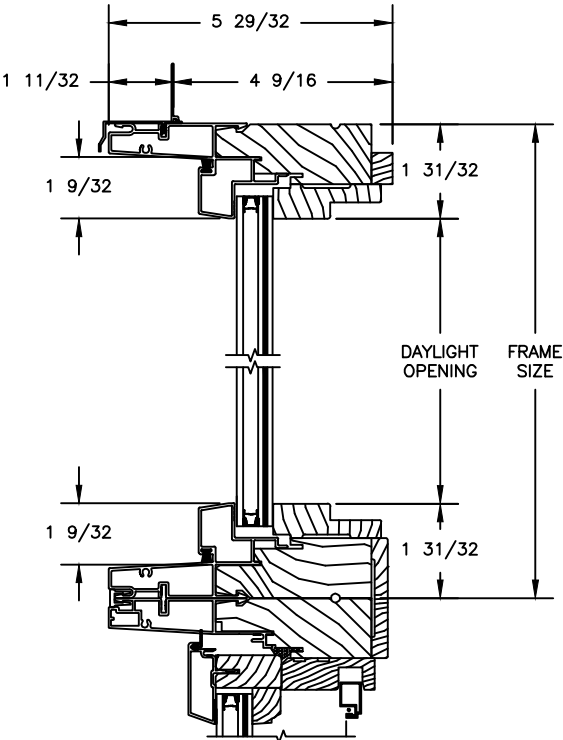

TRANSOM
HEAD JAMB & SILL

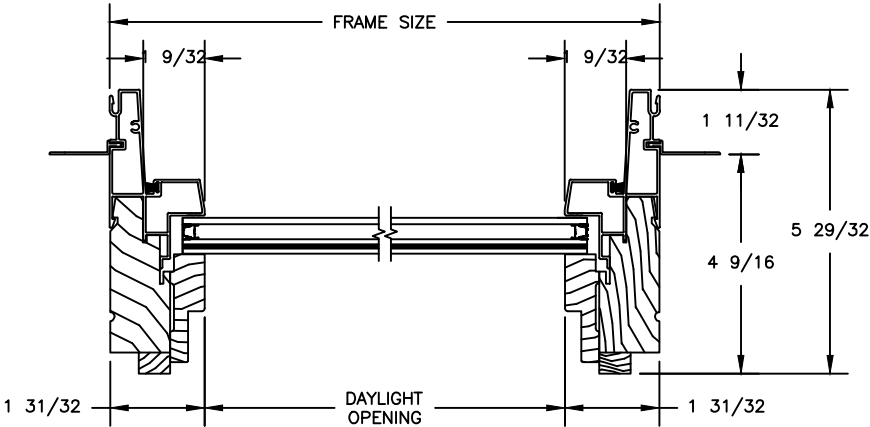

JAMBS

Pinnacle Impact Series

CLAD DIRECT SET

SECTION DETAILS: DIRECT GLAZE WITH CONTEMPORARY STOPS

SCALE: 3" = 1'-0"

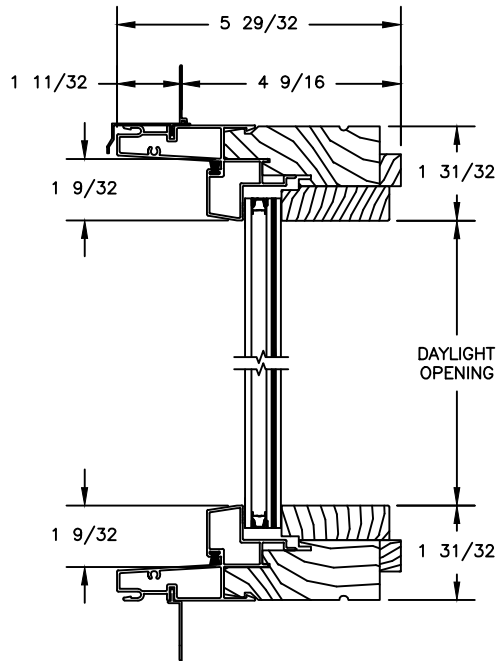

HEAD JAMB & SILL

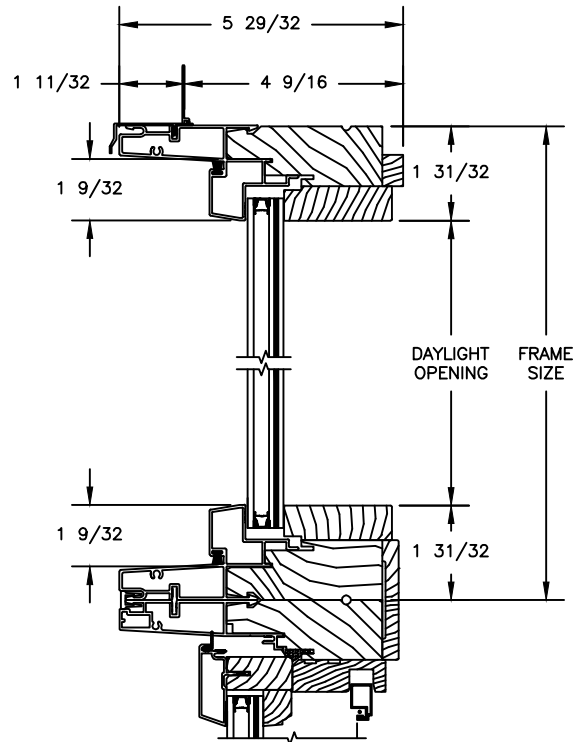

TRANSOM
HEAD JAMB & SILL

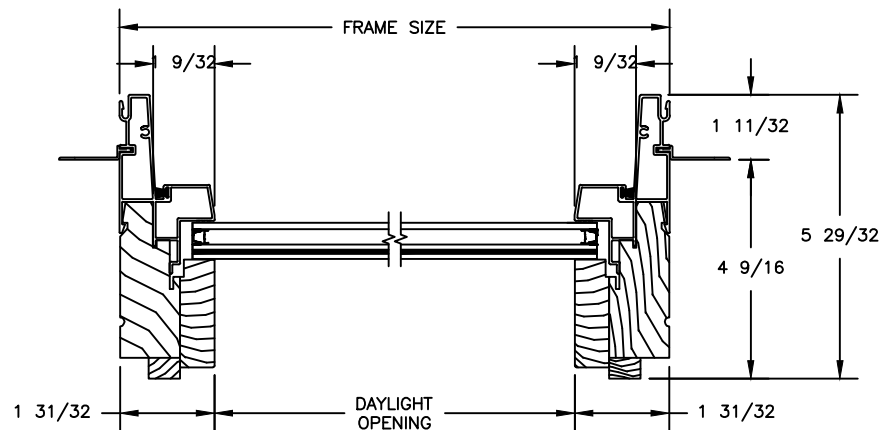

JAMBS

Pinnacle Impact Series

CLAD DIRECT SET

SECTION DETAILS : CASING OPTIONS

SCALE: 3" = 1'-0"

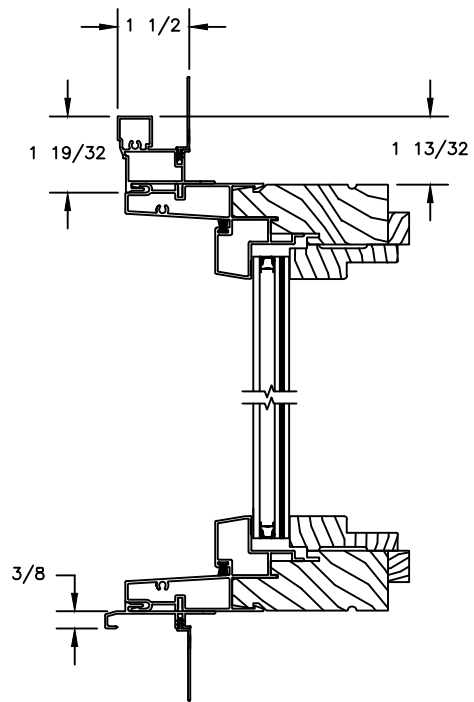

HEAD JAMB & SILL WITH
CLAD BRICKMOULD CASING

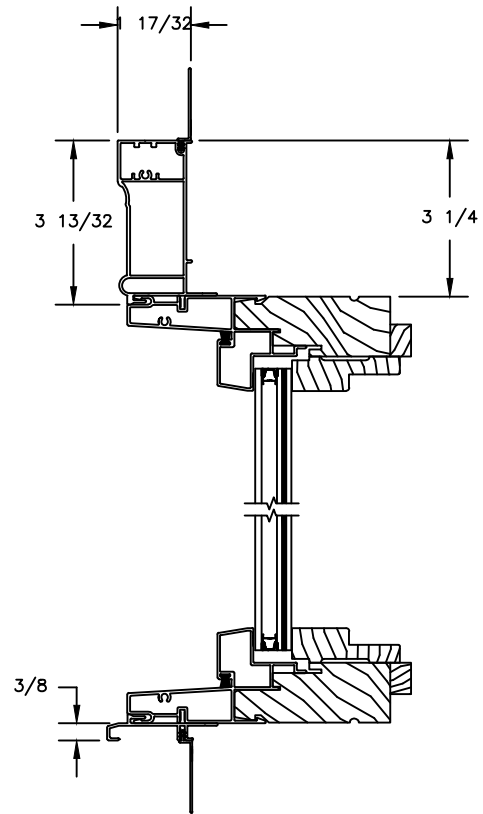

HEAD JAMB & SILL WITH
CLAD WILLIAMSBURG CASING

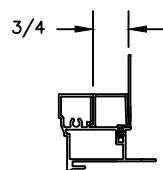

CLAD BRICKMOULD CASING
WITH OPTIONAL J-CHANNEL COVER

Pinnacle Impact Series

CLAD DIRECT SET

SECTION DETAILS : MULLIONS

SCALE: 3" = 1'-0"

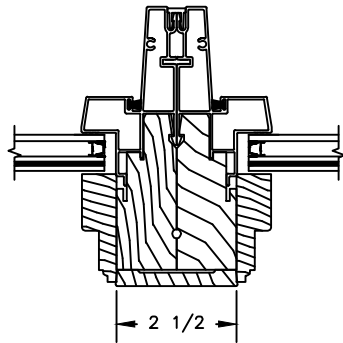

VERTICAL MULLION
DIRECT SET/DIRECT SET

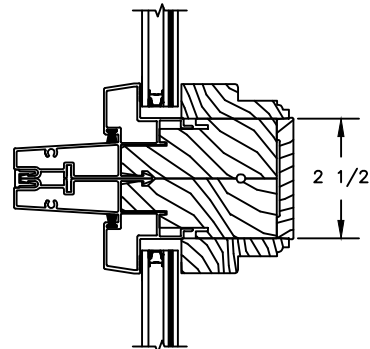

HORIZONTAL MULLION
DIRECT SET/DIRECT SET

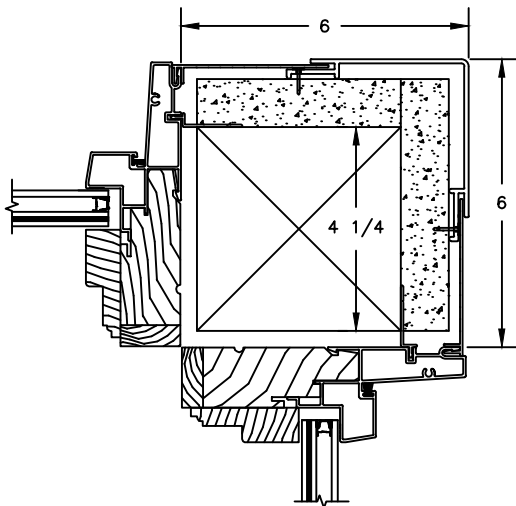

90° MULLION
DIRECT SET/DIRECT SET
(ONLY USED WITH 4 9/16" JAMB & 3 1/4"
FRAME EXPANDER)

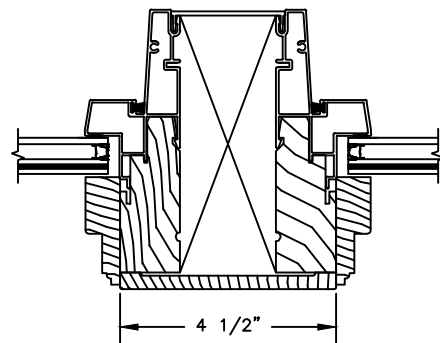

VERTICAL MULLION WITH
2" SPREAD MULL
ADDITIONAL WIDTHS INCLUDE:
1", 2", 2 1/2", 3", & 4"

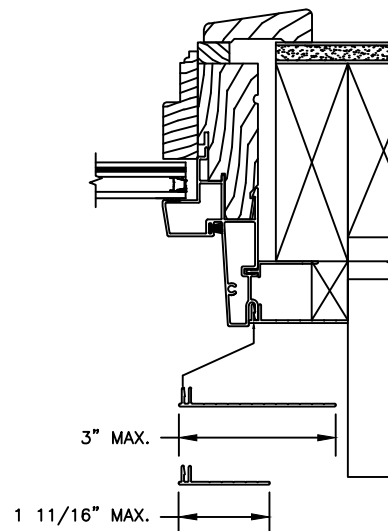

OPTIONAL FRAME
EXPANDERS

Pinnacle Impact Series

CLAD DIRECT SET

SECTION DETAILS : DIVIDED LITE OPTIONS

SCALE: 3" = 1'-0"

AVAILABLE STYLES

-  - PUTTY
-  - TALL PUTTY
-  - OGEE
-  - CONTEMPORARY

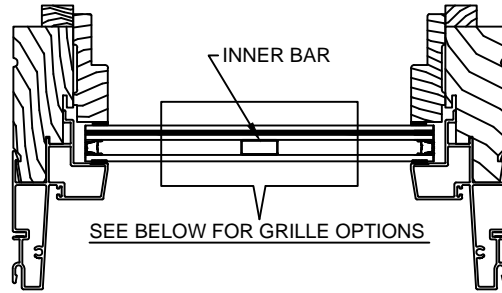

	5/8" WDL WITH INNER BAR	7/8" WDL WITH INNERBAR	1 1/4" WDL WITH INNERBAR	2" WDL WITH INNERBAR
STANDARD INSULATING GLASS				
13/16" INNERGRILLE				
3/4" PROFILED INNERGRILLE				
1" PROFILED INNERGRILLE				
7/8" STICK & PERIMETER GRILLE				
1 1/4" STICK & PERIMETER GRILLE				

NOTE:
 * ALL WDL OPTIONS CAN BE ORDERED WITH OR WITHOUT INNER BAR
 4/17/17