



STRUCTURAL DESIGN PRESSURE FOR PINNACLE CLAD MULLIONS

(Includes Standard, High Performance and Impact Zone 3)

When mulling window units in the various combinations, it is important the entire mulled combination comply with local wind load requirements. To ensure the mulled combination complies with local codes and requirements, the wind load of the entire mulled combination must be determined. The following three steps will assist in determining the structural wind load of the mulled combination:

1. Determine the local building code PSF requirements
2. Choose the individual units needed to meet the local building code PSF and Performance Grade (PG) requirements.
Individual unit performance data can be found at www.windsorwindows.com
3. Choose the mulling combination and mulling type that meets the local building code PSF requirement from the following combination mulling charts.



STRUCTURAL DESIGN PRESSURE

FOR PINNACLE CLAD MULLIONS

(Includes Standard, High Performance and Impact Zone 3)

Zero Mull		TW - Tributary Width (in)										
One - Way		24	30	36	42	48	54	60	66	72	78	84
L - Mull Length (in)	24	75	75	75	75	75	75	75	75	75	75	75
	30	75	75	75	75	75	75	75	75	75	75	75
	36	75	75	75	75	75	75	75	75	75	75	75
	42	75	75	75	75	75	75	75	75	75	75	75
	48	75	75	75	75	75	75	75	75	75	75	75
	54	75	75	75	75	75	75	75	75	75	75	75
	60	75	75	75	75	75	75	75	70	70	70	70
	66	75	75	75	70	64	60	58	53	53	53	53
	72	75	75	64	57	52	49	46	41	41	41	41
	78	75	64	54	48	43	40	38	33	32	32	32
	84	67	54	46	41	37	34	31	27	26	26	25
	90	58	47	40	35	31	29	27	23	22	21	21
	96	51	41	35	30	27	25	23	19	18	18	17
	102	45	36	31	27	24	22	20	17	16	16	15
108	38	31	26	23	20	18	17	15				
114	32	26	22	19	17	16						
120	28	22	19	16	15							

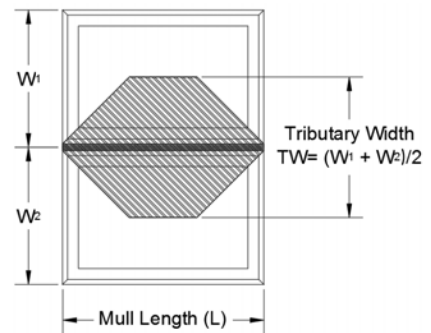
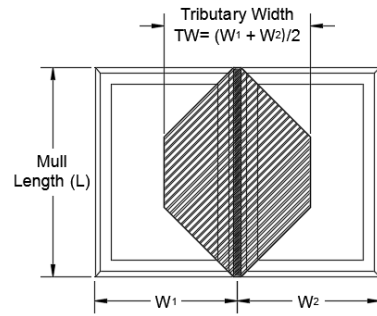

- Values represent structural pressure only (PSF)
- Overall structural performance of combination is determined by the lowest structural performance of any individual unit or mullion in the combination
- Products must be installed and anchored properly in accordance with Windsor Windows Installation Guidelines

Zero Mull		TW - Tributary Width (in)										
Two - Way		24	30	36	42	48	54	60	66	72	78	84
L - Mull Length (in)	24	75	75	75	75	75	75	75	75	75	75	75
	30	75	75	75	75	75	75	75	75	75	75	75
	36	75	75	75	75	75	75	75	75	75	75	75
	42	75	75	75	75	75	75	75	75	75	75	75
	48	75	75	75	75	75	75	75	75	75	70	65
	54	75	75	75	75	72	75	73	67	61	56	52
	60	75	75	75	67	59	64	58	53	48	44	41
	66	75	75	65	55	48	52	47	43	39	36	33
	72	75	65	54	46	41	43	39	35	32	30	27
	78	69	55	46	39	34	36	32	29	27	25	23
	84	60	48	40	34	30	31	28	25	23	21	20
	90	52	42	35	30	26	26	24	21	20	18	17
	96	46	36	30	26	23	23	21	19	17	16	
	102	41	33	27	23	20	20	18	16	15		
108	36	29	24	20	18	18	16	15				
114	32	26	21	18	16	16						
120	29	23	19	16								

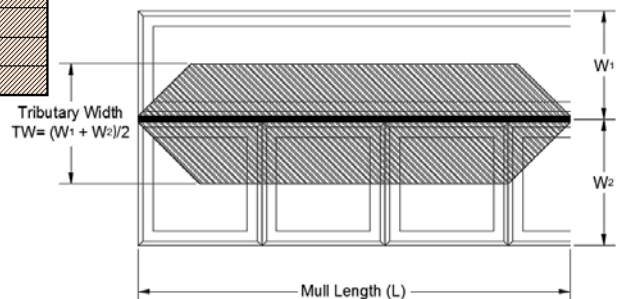
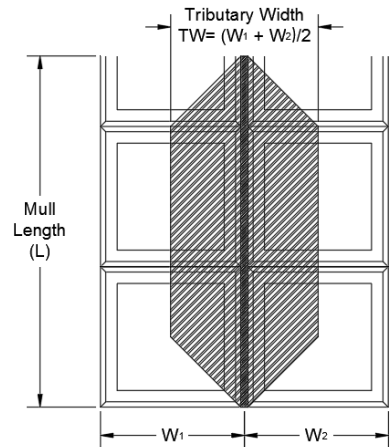

- Values represent structural pressure only (PSF)
- Overall structural performance of combination is determined by the lowest structural performance of any individual unit or mullion in the combination
- Products must be installed and anchored properly in accordance with Windsor Windows Installation Guidelines

STRUCTURAL DESIGN PRESSURE FOR PINNACLE CLAD MULLIONS

(Includes Standard, High Performance and Impact Zone 3)

1" Spread Mull One - Way		TW - Tributary Width (in)										
		24	30	36	42	48	54	60	66	72	78	84
L - Mull Length (in)	24	75	75	75	75	75	75	75	75	75	75	75
	30	75	75	75	75	75	75	75	75	75	75	75
	36	75	75	75	75	75	75	75	75	75	75	75
	42	75	75	75	75	75	75	75	75	75	75	75
	48	75	75	75	75	75	75	75	75	75	75	75
	54	75	75	75	75	75	75	75	75	75	75	75
	60	75	75	75	75	75	75	75	75	75	75	75
	66	75	75	75	75	75	75	75	75	75	75	75
	72	75	75	75	75	75	75	75	75	75	75	75
	78	75	75	75	75	75	75	75	75	75	75	75
	84	75	75	75	75	75	73	69	66	64	62	62
	90	75	75	75	71	63	58	54	51	49	48	47
	96	75	75	66	57	51	47	44	41	39	38	37
	102	75	66	56	49	44	40	37	34	33	31	30
	108	67	54	45	40	35	32	29	27	26	25	24
114	56	46	38	33	30	27	25	23	22	20	20	
120	48	39	33	28	25	23	21	19	18	17	16	

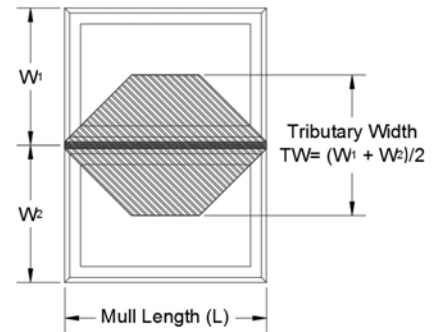
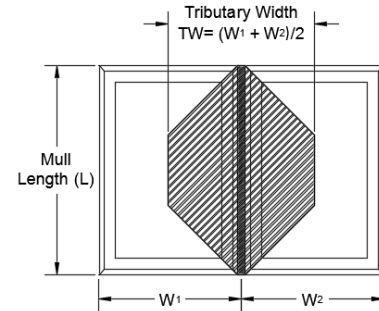

- Values represent structural pressure only (PSF)
- Overall structural performance of combination is determined by the lowest structural performance of any individual unit or mullion in the combination
- Products must be installed and anchored properly in accordance with Windsor Windows Installation Guidelines

1" Spread Mull Two - Way		TW - Tributary Width (in)										
		24	30	36	42	48	54	60	66	72	78	84
L - Mull Length (in)	24	75	75	75	75	75	75	75	75	75	75	75
	30	75	75	75	75	75	75	75	75	75	75	75
	36	75	75	75	75	75	75	75	75	75	75	75
	42	75	75	75	75	75	75	75	75	75	70	65
	48	75	75	75	75	75	75	75	73	66	61	57
	54	75	75	75	75	75	75	71	64	59	54	51
	60	75	75	75	75	75	71	64	58	53	49	45
	66	75	75	75	75	73	64	58	53	48	44	41
	72	75	75	75	75	66	59	53	48	44	41	38
	78	75	75	75	70	61	54	49	44	41	38	35
	84	75	75	75	65	57	51	45	41	38	35	32
	90	75	75	71	61	53	47	42	38	35	32	30
	96	75	74	62	53	46	41	37	34	31	28	26
	102	75	64	53	45	40	35	32	29	26	24	23
	108	65	52	43	37	32	29	26	23	21	20	18
114	55	44	37	31	27	24	22	20	18	17	16	
120	47	38	31	27	24	21	19	17	16			

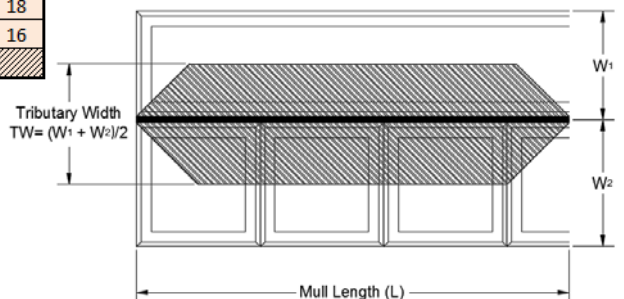
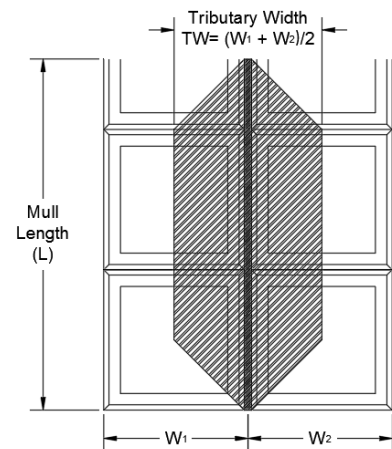

- Values represent structural pressure only (PSF)
- Overall structural performance of combination is determined by the lowest structural performance of any individual unit or mullion in the combination
- Products must be installed and anchored properly in accordance with Windsor Windows Installation Guidelines



STRUCTURAL DESIGN PRESSURE FOR PINNACLE CLAD MULLIONS

(Includes Standard, High Performance and Impact Zone 3)

2" Spread Mull		TW - Tributary Width (in)										
One - Way		24	30	36	42	48	54	60	66	72	78	84
L - Mull Length (in)	24	75	75	75	75	75	75	75	75	75	75	75
	30	75	75	75	75	75	75	75	75	75	75	75
	36	75	75	75	75	75	75	75	75	75	75	75
	42	75	75	75	75	75	75	75	75	75	75	75
	48	75	75	75	75	75	75	75	75	75	75	75
	54	75	75	75	75	75	75	75	75	75	75	75
	60	75	75	75	75	75	75	75	75	75	75	75
	66	75	75	75	75	75	75	75	75	75	75	75
	72	75	75	75	75	75	75	75	75	75	75	75
	78	75	75	75	75	75	75	75	75	75	75	75
	84	75	75	75	75	75	75	71	68	66	65	65
	90	75	75	75	75	73	67	64	61	59	58	57
	96	75	75	75	73	66	61	56	53	51	49	48
	102	75	75	72	63	56	51	48	45	42	41	40
108	75	70	59	51	46	41	38	36	34	32	31	
114	73	59	50	43	38	35	32	30	28	27	25	
120	62	50	42	37	33	29	27	25	23	22	21	

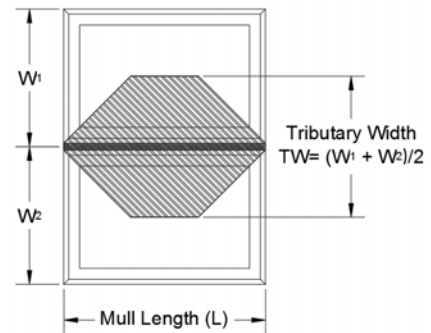
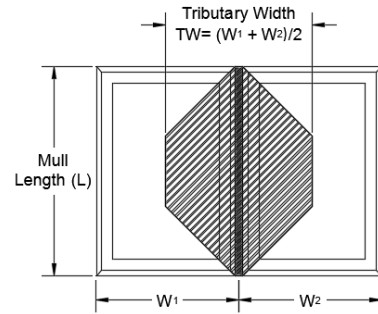

- Values represent structural pressure only (PSF)
- Overall structural performance of combination is determined by the lowest structural performance of any individual unit or mullion in the combination
- Products must be installed and anchored properly in accordance with Windsor Windows Installation Guidelines

2" Spread Mull		TW - Tributary Width (in)										
Two - Way		24	30	36	42	48	54	60	66	72	78	84
L - Mull Length (in)	24	75	75	75	75	75	75	75	75	75	75	75
	30	75	75	75	75	75	75	75	75	75	75	75
	36	75	75	75	75	75	75	75	75	75	75	75
	42	75	75	75	75	75	75	75	75	75	70	65
	48	75	75	75	75	75	75	75	73	66	61	57
	54	75	75	75	75	75	75	71	64	59	54	51
	60	75	75	75	75	75	71	64	58	53	49	45
	66	75	75	75	75	73	64	58	53	48	44	41
	72	75	75	75	75	66	59	53	48	44	41	38
	78	75	75	75	70	61	54	49	44	41	38	35
	84	75	75	75	65	57	51	45	41	38	35	32
	90	75	75	71	61	53	47	42	38	35	32	30
	96	75	75	66	57	50	44	40	36	33	30	28
	102	75	75	63	54	47	42	38	34	31	29	27
108	75	67	56	48	42	37	34	30	28	26	24	
114	72	57	48	41	36	32	28	26	24	22	20	
120	61	49	41	35	30	27	24	22	20	19	17	

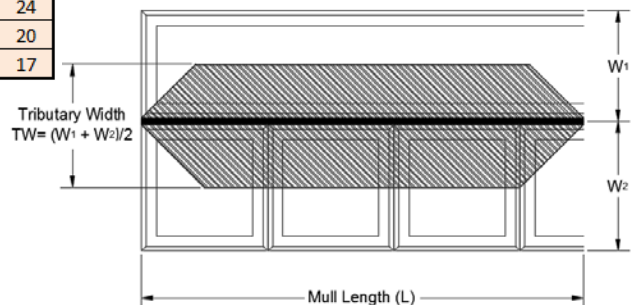
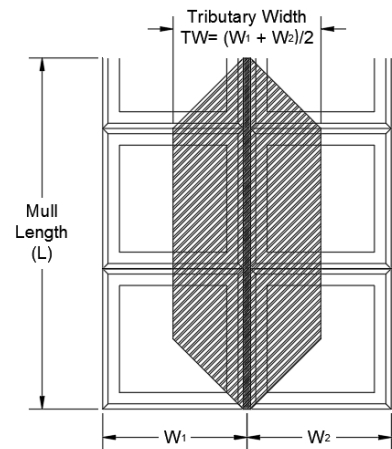

- Values represent structural pressure only (PSF)
- Overall structural performance of combination is determined by the lowest structural performance of any individual unit or mullion in the combination
- Products must be installed and anchored properly in accordance with Windsor Windows Installation Guidelines



STRUCTURAL DESIGN PRESSURE FOR PINNACLE CLAD MULLIONS

(Includes Standard, High Performance and Impact Zone 3)

4" Spread Mull		TW - Tributary Width (in)										
One - Way		24	30	36	42	48	54	60	66	72	78	84
L- Mull Length (in)	24	75	75	75	75	75	75	75	75	75	75	75
	30	75	75	75	75	75	75	75	75	75	75	75
	36	75	75	75	75	75	75	75	75	75	75	75
	42	75	75	75	75	75	75	75	75	75	75	75
	48	75	75	75	75	75	75	75	75	75	75	75
	54	75	75	75	75	75	75	75	75	75	75	75
	60	75	75	75	75	75	75	75	75	75	75	75
	66	75	75	75	75	75	75	75	75	75	75	75
	72	75	75	75	75	75	75	75	75	75	75	75
	78	75	75	75	75	75	75	75	75	75	75	75
	84	75	75	75	75	75	75	71	68	66	65	65
	90	75	75	75	75	73	67	64	61	59	58	57
	96	75	75	75	73	66	62	58	55	53	52	51
	102	75	75	75	68	62	57	53	50	47	45	44
	108	75	75	65	57	51	46	42	39	37	36	34
114	75	65	55	48	43	39	35	33	31	29	28	
120	69	56	47	41	36	33	30	28	26	25	24	

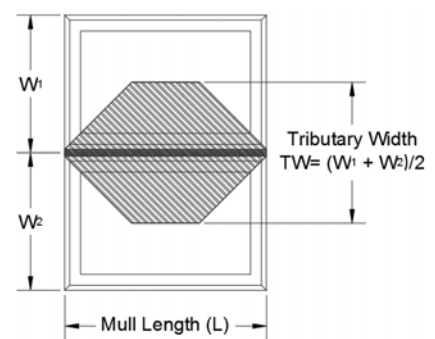
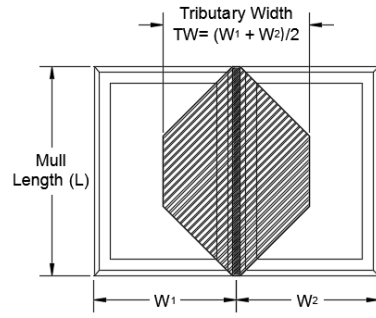

- Values represent structural pressure only (PSF)
- Overall structural performance of combination is determined by the lowest structural performance of any individual unit or mullion in the combination
- Products must be installed and anchored properly in accordance with Windsor Windows Installation Guidelines

4" Spread Mull		TW - Tributary Width (in)										
Two - Way		24	30	36	42	48	54	60	66	72	78	84
L- Mull Length (in)	24	75	75	75	75	75	75	75	75	75	75	75
	30	75	75	75	75	75	75	75	75	75	75	75
	36	75	75	75	75	75	75	75	75	75	75	75
	42	75	75	75	75	75	75	75	75	75	70	65
	48	75	75	75	75	75	75	75	73	66	61	57
	54	75	75	75	75	75	75	71	64	59	54	51
	60	75	75	75	75	75	71	64	58	53	49	45
	66	75	75	75	75	73	64	58	53	48	44	41
	72	75	75	75	75	66	59	53	48	44	41	38
	78	75	75	75	70	61	54	49	44	41	38	35
	84	75	75	75	65	57	51	45	41	38	35	32
	90	75	75	71	61	53	47	42	38	35	32	30
	96	75	75	66	57	50	44	40	36	33	30	28
	102	75	75	63	54	47	42	38	34	31	29	27
	108	75	71	59	51	44	39	35	32	29	27	25
114	75	64	53	45	40	35	32	29	26	24	22	
120	68	54	45	39	34	30	27	24	22	21	19	

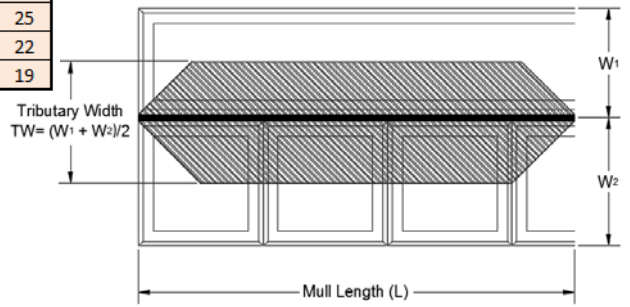
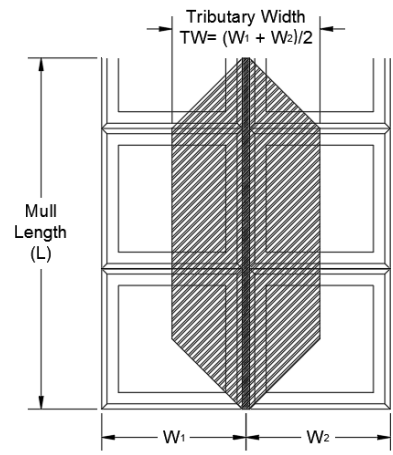

- Values represent structural pressure only (PSF)
- Overall structural performance of combination is determined by the lowest structural performance of any individual unit or mullion in the combination
- Products must be installed and anchored properly in accordance with Windsor Windows Installation Guidelines