

# Installation Guidelines

## FOR LEGEND & LEGEND HBR WINDOWS

### Installer

- Read instructions completely before attempting installation. Failure to follow these guidelines will void the Windsor warranty coverage, written or implied.
- Always provide a copy of these instructions to the homeowner.
- These instructions are consistent with ASTM 2112 "Standard Practice for Installation of Exterior Windows, Doors and Skylights" into common wall constructions. For installation into air barrier sheathing systems such as ZIP System, refer to our supplemental installation instructions at [www.windsorwindows.com](http://www.windsorwindows.com). Contact your architect or construction professional for installation into other building designs or construction methods.
- Regional codes and environmental conditions may require installation that is different from these guidelines. It is your responsibility to ensure that local codes and ordinances are followed.

### Warning

- ⚠ **Work Safe!** Always wear proper eye and hearing protection when installing or adjusting Windsor products.
- ⚠ **Use Power Tools Properly!** To avoid personal injury, always follow manufacturers' instructions for safe operation of power tools.
- ⚠ **Ladder Safety!** Working at elevated levels can be hazardous. Always use ladders and scaffolding properly. Consult manufacturers' guidelines for safe use of these types of equipment.
- ⚠ **Safety Glazing!** Windsor products do not contain safety glazing unless specifically ordered that way. Use caution – injury could result if glass is broken and fragmented. Building codes require safety glazing for windows installed in certain areas. Consult your local building code official for guidelines.

### Important

- Windsor reserves the right to change the information contained in these guidelines without notice.
- Maintain a minimum of 1/4" between the window frame and any trim, siding or masonry.
- Use of Windsor products in barrier EIFS systems (synthetic stucco) is not recommended. To do so will void all warranties (written or implied) and Windsor Windows & Doors will not be held responsible for any claims or damages resulting from water infiltration.
- Steel fasteners will corrode when used with ACQ pressure treated lumber. Use corrosion-resistant fasteners (such as stainless steel) when installing windows in or around these types of materials.
- Window nailing flanges and drip caps (integral or applied) do not take the place of window flashing. All windows and doors must be properly flashed and sealed around the perimeter.
- Certain Windsor double hung products are furnished with jamb jacks. Jamb jacks are not required for installation, but can be used after installation to adjust the frame width at the middle of the unit. Jamb jacks should not be used in place of shims. Refer to Step 4 for shimming guidelines.

### Handling and Storage

- **Prefinished Interiors: CAUTION:** Windows with prefinished interiors must be protected from dents, scratches, scrapes or other blemishes. Windsor does not warrant against dents, scratches, scrapes or other damage to prefinished interiors after the Windsor products leave Windsor's possession.









After the Windsor products leave Windsor's possession, extreme care must be taken by those moving the windows, or those working on or around the windows, to protect pre-finished interiors from dents, scratches, scrapes or other blemishes.

### **Follow these procedures for proper storage and handling of windows and doors:**

- Remove stretch wrap immediately so the individual units can be exposed to circulated air.
- Do not store units outside or in direct sunlight. Allow sufficient spacing between products for ventilation.
- Never store vinyl units in a closed truck or other enclosure.
- Never stack or lean vinyl units against each other in the sun.
- Always store vinyl units vertically. Do not store windows flat or stack horizontally.
- Vinyl units must be stored in a clean, dry, well-ventilated and enclosed area.
- Vinyl windows with unsupported nailing fins should have their corners blocked and protected to prevent damage to the nailing fin.
- Always carry window units upright. Do not carry flat! Doing so could result in damage to the unit.

**Failure to follow these procedures will void our product warranty.**

### **Tools Needed**

- |                        |  |                        |   |
|------------------------|--|------------------------|---|
| • Safety Glasses       |  | • Ladder / Scaffolding |  |
| • Utility Knife        |   | • Square               |  |
| • Hammer (or nail gun) |  | • Tape Measure         |  |
| • Caulk Gun            |  | • Stapler              |  |
| • Level                |  |                        |   |

### **Materials Needed**

- Backer Rod
  - 1/4"-1/2" diameter closed cell foam
- Insulation
  - Minimally expanding low pressure polyurethane window and door foam
- Shims
  - Made of cedar or synthetic material
- Casing Nails
  - 16d Galvanized
- Silicone Sealant
  - 100% Silicone
- Flashing
  - Self-adhesive flexible flashing that complies with AAMA-711
- Rigid Metal Flashing and Fasteners
  - Applied to head brickmould

## **LEAD PAINT AND EXISTING WINDOW DISPOSAL:**

- A) Before any remodel or renovation, make sure to identify any potential lead paint issues and take necessary steps to reduce the risk of lead contamination.
- B) The U.S. Environmental Protection Agency (EPA) has issued a “Lead Renovation, Repair and Painting Rule (RRP)” for remodelers of older homes and buildings. This rule requires training and certification in lead-safe work practices for firms performing renovation, repair or painting on homes and child-occupied facilities built prior to 1978.
- C) For more information regarding procedures for dealing with lead paint, please visit EPA’s website at [\*\*www.epa.gov/lead\*\*](http://www.epa.gov/lead).
- D) When removing existing windows, make sure to wear appropriate personal protective equipment. Extra precautions should be taken to protect others and property within the vicinity and below the removal window and surrounding components.
- E) Consult with local waste authorities on the proper recycling or disposal of old window components.

**ATTENTION! ARBITRATION AGREEMENT; JURY TRIAL WAIVER; CLASS ACTION WAIVER.** By purchasing, installing or using this product, you agree to arbitrate any dispute you may have with Windsor relating to your Windsor products, and to waive your rights to a jury trial and to participate in class-action or class-arbitration proceedings, relating to any such disputes. For more details, and to learn how **YOU CAN OPT OUT OF THIS ARBITRATION AGREEMENT AND THESE WAIVERS**, please go to [www.windsorwindows.com/support/DisputeResolution](http://www.windsorwindows.com/support/DisputeResolution).

## Step 1: Inspect Unit

### Before Installation:

- A) Remove all shipping/packaging material (blocks, pads, protectors, stretch wrap).
- B) Do not remove double hung belly bands (white strap) and sash clips until after install.
- C) Inspect unit for any damage or defects.
- D) Verify that the window unit is the correct size and configuration.
- E) Make sure the unit operates properly.
- F) Contact your nearest Windsor distributor if there are any problems.

## Step 2: Prepare Rough Opening

- A) Measure and verify the size of the rough opening. The rough opening should be  $3/4$ " larger in width and  $1/2$ " larger in height than the frame size.
- B) For windows with clad exterior casings, additional nailer studs may be required around the perimeter of the rough opening.
- C) Framing recommendations for radius and geometric windows are shown in Fig. 1 below.

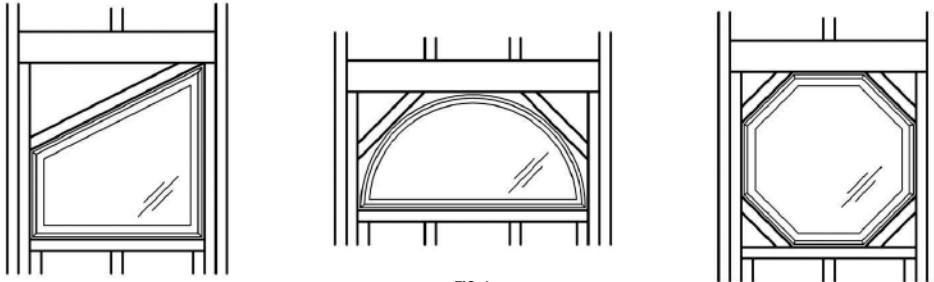

FIG. 1

- D) Verify the rough opening is flat, plumb, level and square. (Fig. 2)
- E) Take diagonal measurements to check for square. (Fig. 2)
- F) Make sure the bottom sill area of the opening does not slope toward the interior.
- G) Make an "I-Cut" in the weather-resistant barrier (WRB). Begin with a horizontal cut along the bottom and the top of the rough opening. Then make a vertical cut in the center from top to bottom. (Fig. 3)
- H) From the exterior, cut the top of the WRB as shown to form a flap.(Fig. 4)
- I) Temporarily tape this top flap up. (Fig. 4)
- J) Fold side flaps into rough opening and secure to inside wall. Cut off excess flap if desired.

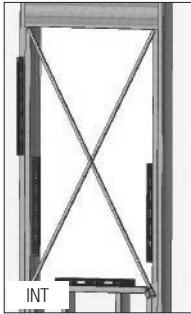

FIG. 2

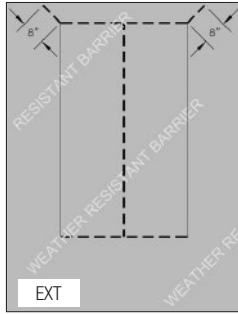

FIG. 3

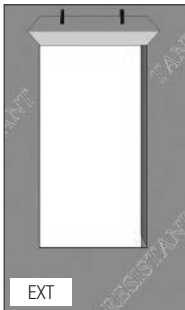
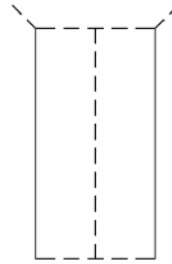
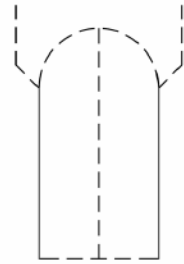

FIG. 4

- K) Optional cutting patterns for radius and geometric shapes are shown in Fig. 5 below.



RECTANGLE



ROUND TOP

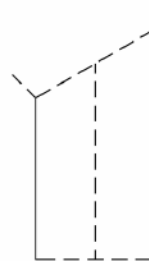

TRAPEZOID

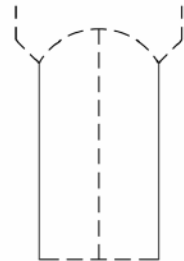

SEGMENT TOP

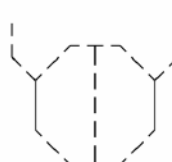

OCTAGON

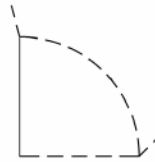

QUARTER ROUND

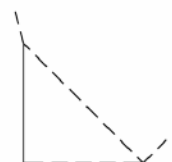

RIGHT TRIANGLE

FIG. 5

## Step 3: Flashing the Sill

### A) IMPORTANT:

- a. Use flashing that is 6" minimum in width.
  - b. Flashing must meet AAMA-711 performance requirements.
  - c. Adhesive or mechanically-fastened flashing may be used.
- B) Measure the width of the rough opening. Cut a length of flashing that is 12" wider than the rough opening. This will allow you to run the flashing 6" up each side.
- C) Cut 1-1/2" slits at each end of the flashing as shown below. (Fig. 6)

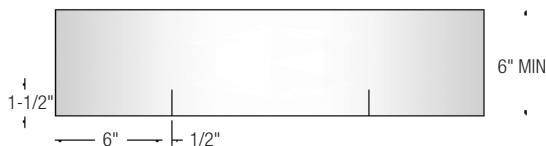

FIG. 6

- D) Apply sill flashing to the rough opening as shown below. (Fig. 7)
- E) If you are using non-adhesive flashing:
- a. Staple flashing into place.
  - b. Seal corner notches using 100% neutral cure silicone sealant.
- F) Flashing tape must cover the entire sill plate. If needed, apply an additional flashing piece over the first one (start from the exterior and work toward the interior). Maintain a minimum 1" overlap. (Fig. 8)

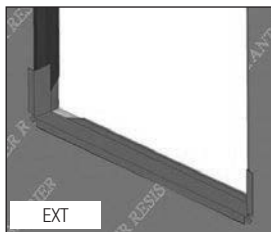

FIG. 7

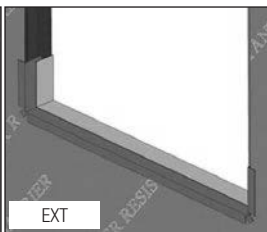

FIG. 8

- G) Cut and apply flashing to both sides and the top of the rough opening. Overlap the top flashing over the side flashing. The flashing should run at least 6" past each side of the rough opening. (Fig.9)

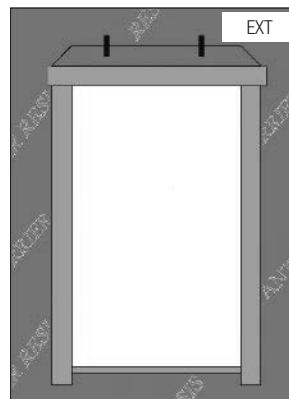

FIG. 9

## Step 4: Window Installation

*For Impact-rated products and/or any products installed in the Florida or Texas TDI regions, supplemental anchoring methods may be required. Refer to supplemental instructions attached to unit or [www.windsorwindows.com](http://www.windsorwindows.com) for further information.*

- A) For applied straps and no-nail fin installation, refer to the supplemental instructions located at [windsorlegend.com/warranty](http://windsorlegend.com/warranty).
- B) Remove all packaging material (blocks, pads, protectors, stretch wrap).
- C) Do not remove double hung belly band (white strap) and sash clips until after install.
- D) Inspect and verify the following:
  - a. The window is the correct size and specification.
  - b. The unit is free from any damage or defects.
- E) Contact your nearest Windsor distributor if there are any problems with Step D above.

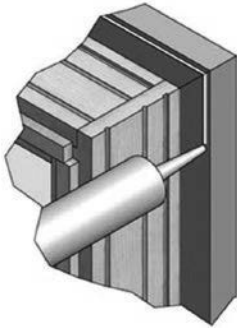

FIG. 10

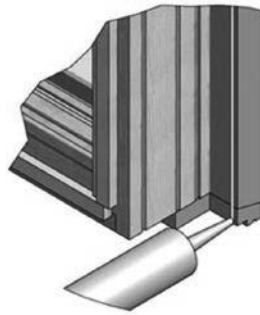

FIG. 11

- F) Apply sealant: On the backside of the head and side brickmould, run a 1/4" continuous bead of silicone along the entire length 1/4" from the outside edge of the brickmould. (Fig. 10 & 11)
- G) Apply sealant to sill: Apply a discontinuous bead of sealant at the top of the sill along the edge of the rough opening. Alternate using a 6" long bead with 1" gaps as shown below. (Fig. 12)

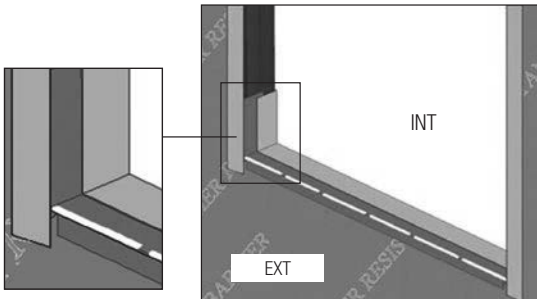

FIG. 12

- H) Set the window into the rough opening. Center the unit in the opening, making sure there are equal gaps on both sides of the window.
- I) Temporarily tack the window into place using 16d nails through the brickmould. Place the nails within 4" of each corner. Do not drive the nails in fully.
- J) Check the unit for square using diagonal measurements. Shim window to ensure the unit is square. Casement units over 48" in height must have shims placed at the center to prevent bowing of jambs.
- Note: Use flat shims.** (Fig. 13)
- K) **For double hung units: To ensure proper window operation and performance, it is critical to shim at the check rail to ensure the frame widths are equal at the top, center and bottom of the unit.** (Fig. 13)
- L) Finish nailing all four corners in place through the brickmould.
- M) Make sure jambs, head and sills are straight. Additional shimming may be required. (Fig. 13)
- N) Finish nailing the window into place through the brickmould. Space the nails 8"-10" apart.

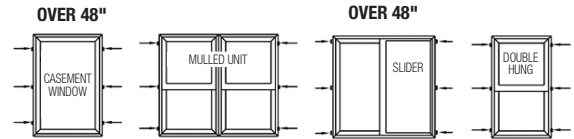

FIG. 13

Installation Fasteners			
Substrate	Fastener	Type of Steel	Minimum Embedment into Framing
Wood	16d Finish Nail	Galvanized, Stainless Steel, Zinc Plated	2"
Wood	#6 Wood Screw		2"
Steel	#8 Self Tap/Drill Screw		Fully Threaded

## Step 5: Complete Head Flashing

- A) Apply sealant: Apply a bead of sealant at the vertical and horizontal contact surface of the rigid metal flashing. (Fig. 14)
- B) Apply the rigid metal flashing. The flashing should extend approximately 1/8" past the edge of the brickmould on each side. Nail the flashing to the rough opening using at least a 1" roofing nail every 8"-10" at approximately 1/2" from the top of the rigid flashing. Ensure that the nail is compatible with the rigid flashing material to prevent corrosion. (Fig. 14 & 15)
- C) Overlap the WRB over the rigid metal flashing. Trim the excess WRB beyond the bead of sealant. (Fig. 15)
- D) Tape the cut seams of the WRB. (Fig. 15)

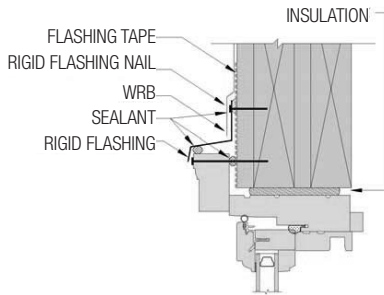
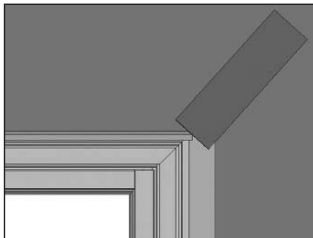

FIG. 14: HEAD JAMB



**Note: Rigid flashing must run at least 1/8" past the brickmould.**

FIG. 15

## Step 6: Seal the Exterior

- A) After siding or wall exterior is complete, apply backer rod and silicone sealant between the exterior window casing and siding material on both sides and sill. (Fig. 16, 17 & 18)
- B) **WARNING:** Maintain a minimum of 1/4" between the exterior window casing and any trim, siding or masonry. Failure to do so will forfeit all warranties (written or implied). Windsor Windows & Doors will not be held responsible for any claims or damages resulting from failure to follow these instructions.

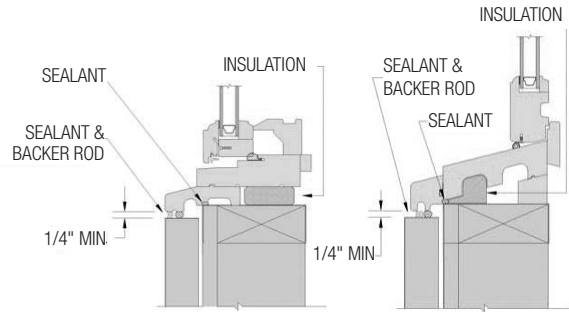

FIG. 16: CASEMENT SILL

FIG. 17: DOUBLE HUNG SILL

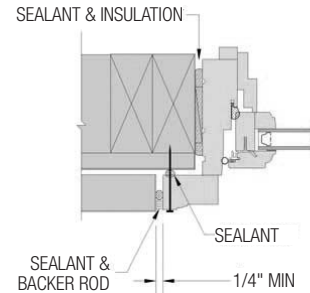

FIG. 18: SIDE JAMB



## Step 7: Completing the Installation

- A) Install a seal around the full interior perimeter of the opening. On the side/jamb and top, apply minimally expanding window and door spray foam insulation. Use caution not to overfill the gap, causing the sides/jamb to bow. It is not recommended to apply trim to the unit until the foam has cured to allow excess to escape. On the sill, apply a bead of sealant between the sill flashing and the window frame.
- B) Operate window unit to ensure proper operation. Sash will not operate correctly if window is out of square, over-shimmed or over-insulated.
- C) Remove all labels or shipping materials.
- D) Properly finish all wood/cellular PVC interior and exterior components within 60 days of installation. See the Care and Use Guide at [www.windsorwindows.com](http://www.windsorwindows.com) for further details on finishing Legend products.
- E) **IMPORTANT:** Do not stain or paint any hardware or vinyl components.

### CAUTION! READ BELOW BEFORE PAINTING

**When painting cellular PVC products with darker paint colors (L values of 56 or below) UV irradiance can generate high localized temperatures in the product.**

**WARNING:** Painting of any cellular PVC surface with a paint color darker than L value of 56 (where black = 0 and white = 100) will forfeit the product warranty.

**If you should, despite the above warning, choose to use darker colors for cellular PVC paint, a paint specifically designed for these applications MUST be used. Contact the paint manufacturer to verify the paint's reflective properties and the suitability for painting cellular PVC.**

**Failure to maintain proper adjustment of casement windows can adversely impact the performance of your windows and may void your warranty.**

**Casement Windows Operating Sash Adjustment:** The sashes of Casement Operating Windows must be adjusted to ensure proper operation and performance. The sashes must be adjusted so the gap between the sash and the frame is consistent. The width of the gaps on the left and right should be similar. The width of the gaps on the top and bottom should be similar. All the gaps should be uniformly straight from one end to another. If you have questions, please see Windsor's Care and Use Guide at [www.windsorwindows.com/support/service-information](http://www.windsorwindows.com/support/service-information). **CAUTION: Misaligned sash will result in a misaligned seal which will adversely affect the performance of the window. As a result, the failure to maintain proper sash adjustment will void Windsor's warranty.**

To adjust the casement sash, first fully open the window. Next, slip the adjustment wrench (Windsor part number 540036) onto the base of the stud, found between the support arm and the track of the lower hinge. Swinging the wrench away from the lock side of the window will decrease the amount of sash drag.

The maximum adjustment is reached when the stud flats are parallel to the track. Note: Turning the stud flats beyond parallel will not increase adjustment.

For even more adjustment, a similar procedure can be used on the upper hinge. Upper hinge adjustment is made by swinging the wrench toward the lock side of the window. Maximum adjustment is obtained when the stud flats are parallel to the track.

Stud may be adjusted with 3/8" or 7/16" wrench if support arm is removed before adjustment.

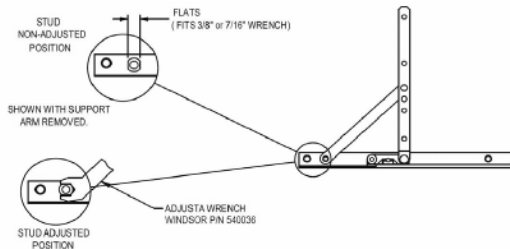

**If you have any questions regarding your Windsor Windows, please contact Windsor Windows & Doors directly at 1-800-218-6186.** Or you can visit us online at [www.windsorwindows.com](http://www.windsorwindows.com), where you will find helpful information as well as our Care and Use Guides, which will assist you in preserving your windows and patio doors. While you are at our site, you can also complete and submit the form on the Contact page, and one of our window specialists will promptly answer your question.

## **Window Opening Control Device**

Please check applicable building codes to determine whether a window opening control device is required.

## **Care and Use**

For information about the care and use of your Windsor products, please visit the [www.windsorwindows.com/support](http://www.windsorwindows.com/support), and click “Warranty, Care & Installation,” where you find a link to our Care and Use Guide. Or contact your local independent Windsor distributor and ask for a copy of the Care and Use Guide, which contains information on finishing, cleaning, what to look for during yearly inspections, general maintenance tips, sash/panel adjustment, sash/panel removal, screen removal and information on condensation. You should inspect your windows annually.

## **Warranties**

**You can find a copy of our current Warranty at the website, under the “Support” tab.** If you have Windsor products that are older, please contact Windsor at 1-800-218-6186, and we will provide a copy of the applicable warranty.



[www.windsorwindows.com](http://www.windsorwindows.com)